

DF4900LS

LINEAR BEARING SMITH MACHINE WITH LAT ATTACHMENT & 200 LB. WEIGHT STACK

Assembly Manual

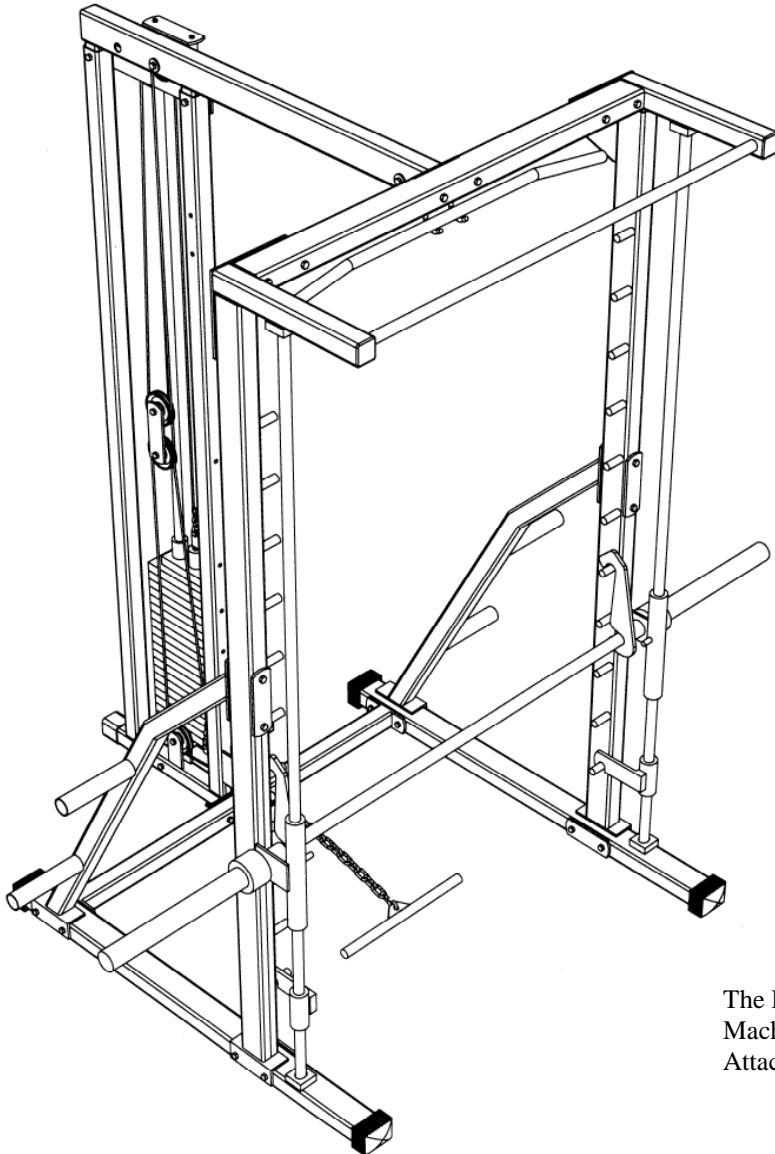

The DF4900LS consists of the DF4900 Smith Machine and the DF838 Stack Loaded Lat Attachment

(888) 258-0533

FOR YOUR SAFETY READ ALL INSTRUCTIONS CAREFULLY

*NOTE IF YOU ARE MISSING HARDWARE OR HAVE ANY FIT UP PROBLEMS PLEASE CONTACT DELTECH FITNESS TOLL FREE (888) 258-0533

DF4900 BOX CONTENTS

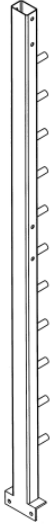

A
LH UPRIGHT
QTY 1



B
RH UPRIGHT
QTY 1

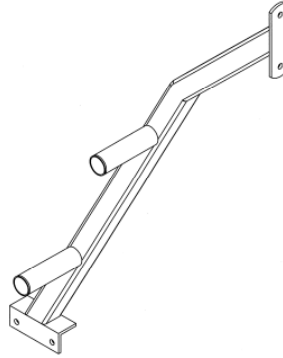

C
LH REAR SUPPORT
QTY 1

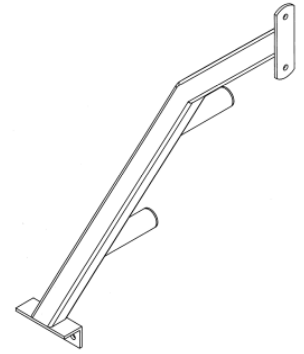

D
RH REAR SUPPORT
QTY 1

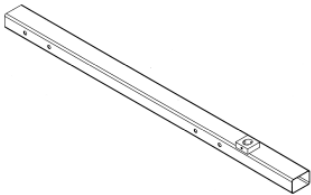

E
LH FOOT
QTY 1

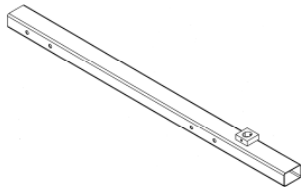

F
RH FOOT
QTY 1

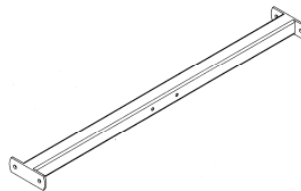

G
CROSSMEMBER
QTY 1

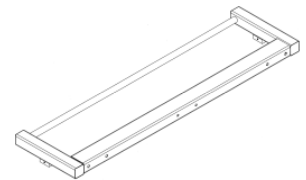

H
TOP FRAME
QTY 1

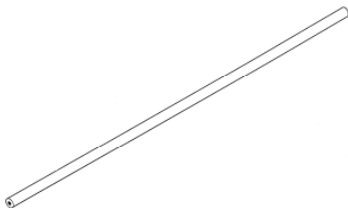

I
PULL-UP BAR
QTY 1



*NOTE IF YOU ARE MISSING HARDWARE OR HAVE ANY FIT UP PROBLEMS PLEASE CONTACT DELTECH FITNESS TOLL FREE (888) 258-0533

DF4900 BOX CONTENTS

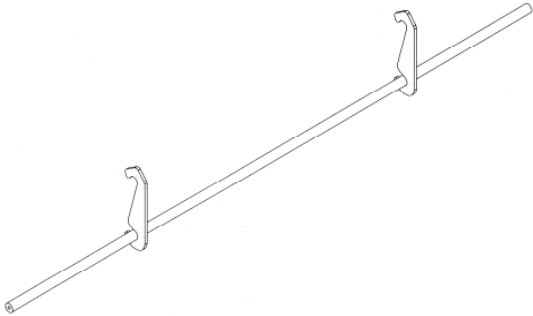

J
SMITH BAR
QTY 1

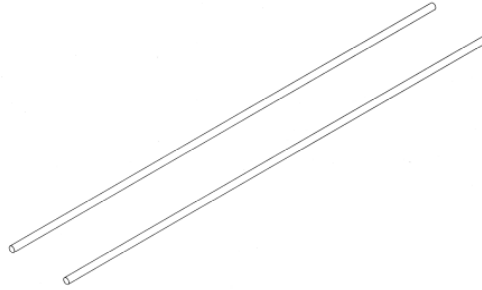

K
GUIDE ROD
QTY 2

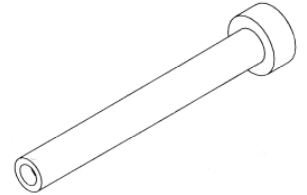

L
WEIGHT SLEEVE
QTY 2

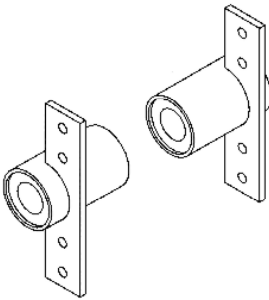

M
LH & RH SMITH BAR COLLAR
QTY 1 EACH

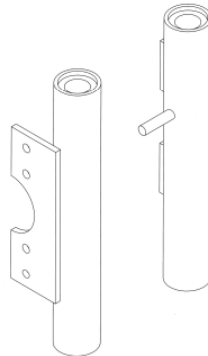

N
LH & RH GUIDE ROD COLLAR
QTY 1 EACH

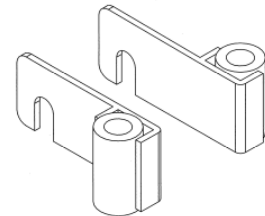

O
LH & RH SAFETY CATCH
QTY 1 EACH

DF4900 HARDWARE

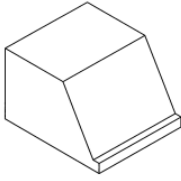

P
RUBBER SHOE
QTY 4

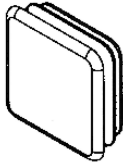

Q
2" SQUARE CAP
QTY 2
(factory installed)



R
1-3/4" ROUND CAP
QTY 4
(factory installed)



S
RUBBER DONUT
QTY 2

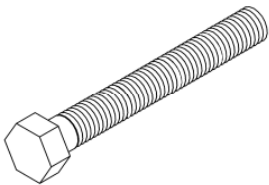

T
PULL-UP BAR BOLT
QTY 2

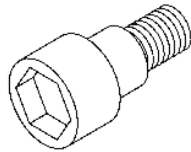

U
WEIGHT SLEEVE
BOLT
QTY 2

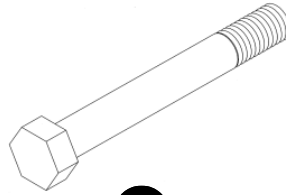

V
M12 x 90MM BOLT
QTY 20

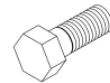

W
M10 x 25MM BOLT
QTY 8



X
M12 WASHER
QTY 40



Y
M10 WASHER
QTY 16



Z
M12 LOCKNUT
QTY 20



AA
M10 LOCKNUT
QTY 8



BB
CHROME SPRING
QTY 2

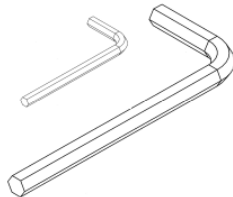

CC
HEX WRENCH
QTY 1

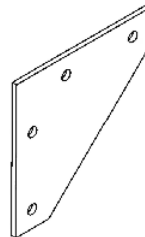

DD
CORNER FLANGE
QTY 2

FRAME ASSEMBLY

TOOLS REQUIRED:

WRENCHES OR METRIC SOCKET SET
HEX WRENCHES (INCLUDED)
ASSEMBLY REQUIRES 2 PEOPLE

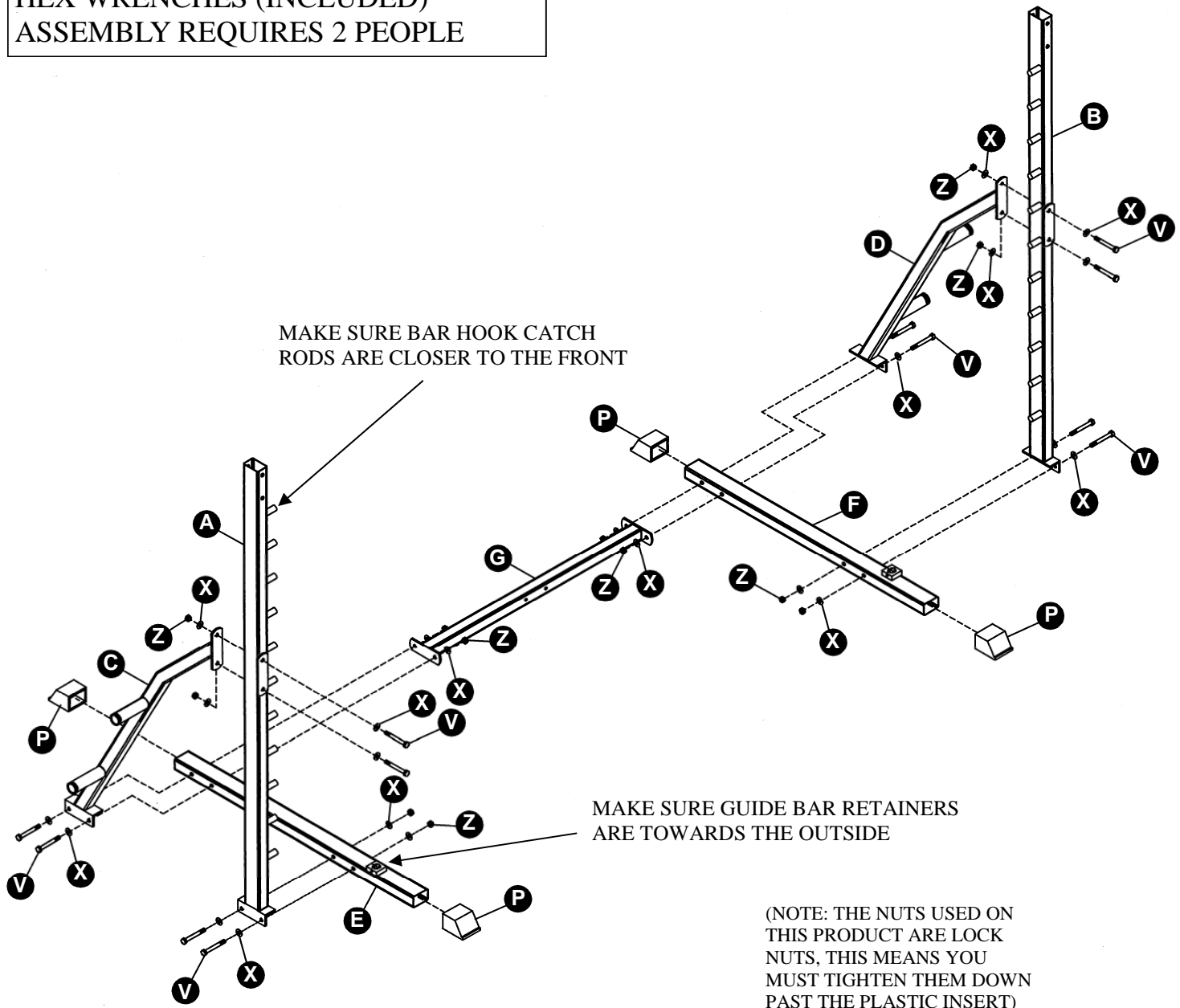

ASSEMBLE THE LH FOOT (E), RH FOOT (F), CROSS MEMBER (G), AND THE LEFT AND RIGHT REAR SUPPORTS (C) AND (D), USING THE M12 x 90MM BOLTS (V), M12 WASHERS (X), AND M12 LOCKNUTS (Z). (LEAVE THE BOLTS HAND TIGHTENED AT THIS TIME)

SLIDE THE RUBBER SHOES (P) ONTO THE LH AND RH FEET (E) & (F).

ASSEMBLE THE LH AND RH UPRIGHTS (A) & (B) TO THE LH AND RH FEET (E) & (F) USING THE M12 x 90MM BOLTS (V), M12 WASHERS (X), AND M12 LOCKNUTS (Z).

ASSEMBLE THE LH AND RH UPRIGHTS (A) & (B) TO THE REAR SUPPORTS (C) & (D) USING THE M12 x 90MM BOLTS (V), M12 WASHERS (X), AND M12 LOCKNUTS (Z).

SMITH BAR ASSEMBLY

LONG SIDE OF BEARING HOUSING
FACES INWARD ON BOTH SIDES

RIGHT HAND ASSEMBLY HAS STOP PIN

MOUNTING FLANGE
FACES OUTWARD ON
BOTH SIDES

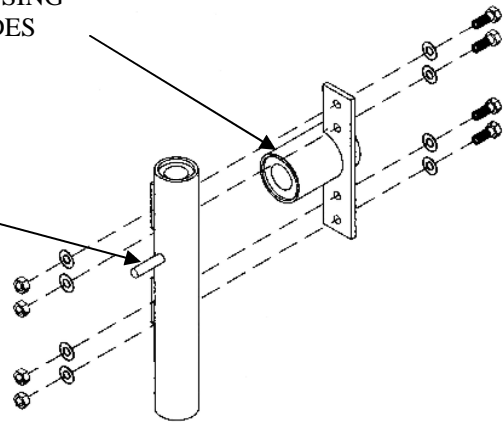

RIGHT HAND ASSEMBLY

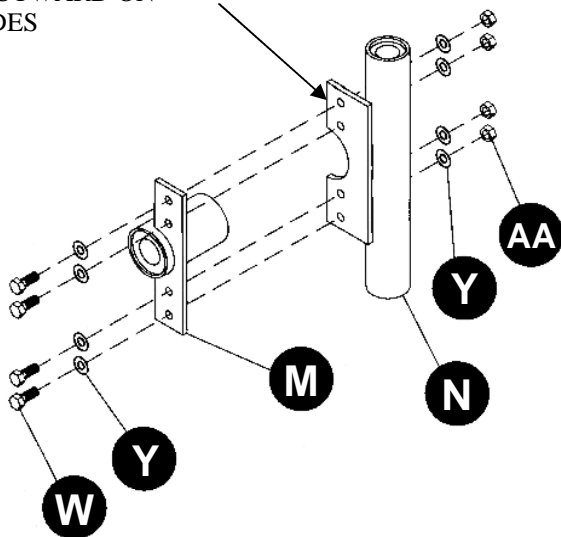

LEFT HAND ASSEMBLY

ASSEMBLE SMITH BAR COLLAR (M) AND GUIDE ROD COLLAR (N) USING THE M10 x 25MM BOLTS (W), M10 WASHERS (Y), AND M10 LOCKNUTS (AA). REPEAT FOR OTHER SIDE.

MAKE SURE HOOKS FACE BACKWARDS
TOWARDS SMITH MACHINE

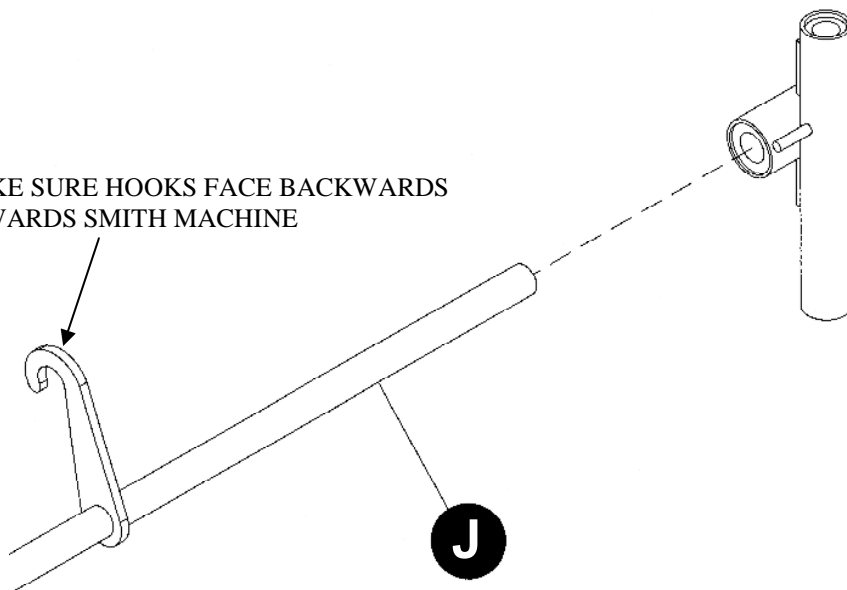

SLIDE THE ASSEMBLY ONTO THE SMITH BAR (J). REPEAT FOR OPPOSITE SIDE.

GUIDE BAR INSTALLATION

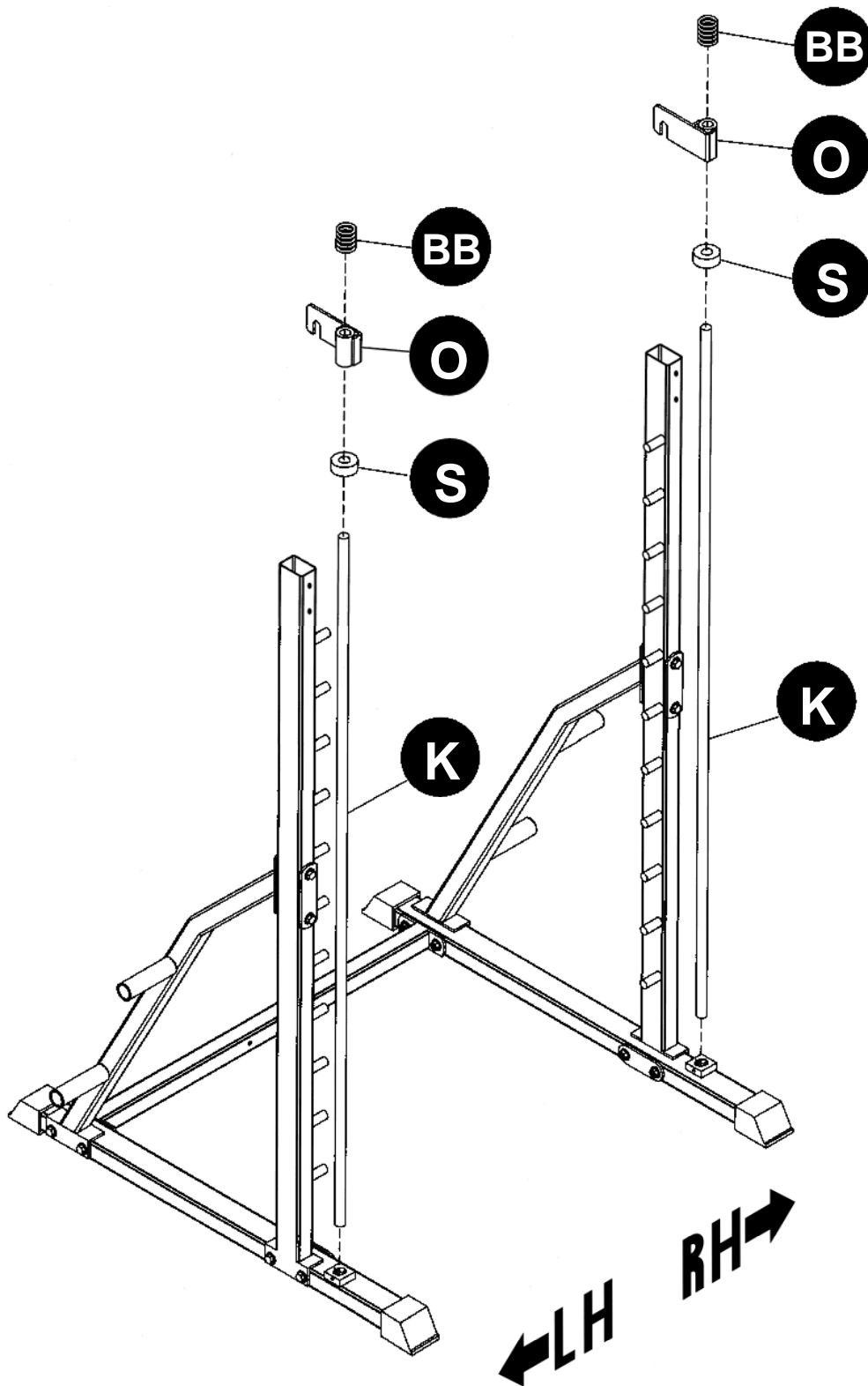

INSERT THE GUIDE RODS (**K**) INTO THE RETAINERS AT THE BOTTOM. SLIDE THE RUBBER DONUTS (**S**) ONTO THE GUIDE RODS AND MOVE TO THE BOTTOM. INSTALL THE RH AND LH SAFETY CATCHES (**O**) AND HOOK ONTO ONE OF THE CATCH PINS TO SUPPORT THE GUIDE RODS. SLIDE THE CHROME SPRINGS (**BB**) ONTO THE GUIDE RODS (**K**).

SMITH BAR ASSEMBLY

GUIDE ROD COLLARS
HAVE LINEAR BEARINGS
ON EACH END

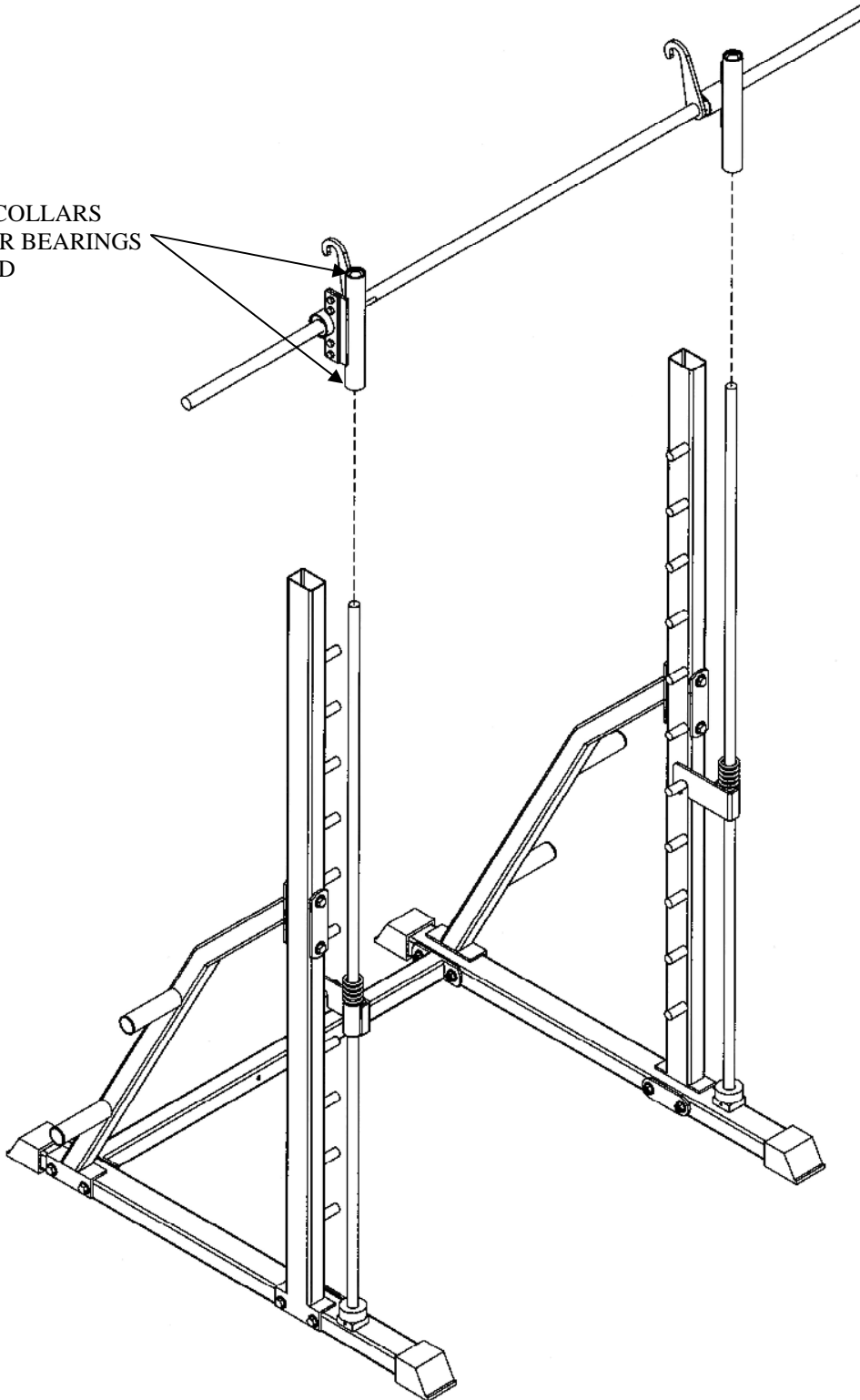

USING A HELPER, LIFT THE SMITH BAR ASSEMBLY FROM EACH SIDE MAKING SURE THAT THE HOOKS ARE FACING TOWARDS THE BACK. INSTALL THE SMITH BAR ASSEMBLY ONTO THE GUIDE RODS ENSURING THAT THE RODS GO INTO THE LOWER ROLLER BEARINGS ON BOTH SIDES BEFORE SLIDING DOWN INTO THE UPPER ROLLER BEARINGS. DO NOT FORCE GUIDE RODS INTO BEARINGS AS DAMAGE CAN OCCUR. AFTER GUIDE RODS ARE FULLY INSERTED INTO UPPER AND LOWER BEARINGS, LOWER THE BAR ASSEMBLY UNTIL IT RESTS ON THE SPRINGS. LIFT SMITH BAR, ROTATE BACKWARDS AND HOOK ONTO ONE OF THE BAR CATCH PINS.

SMITH BAR ASSEMBLY

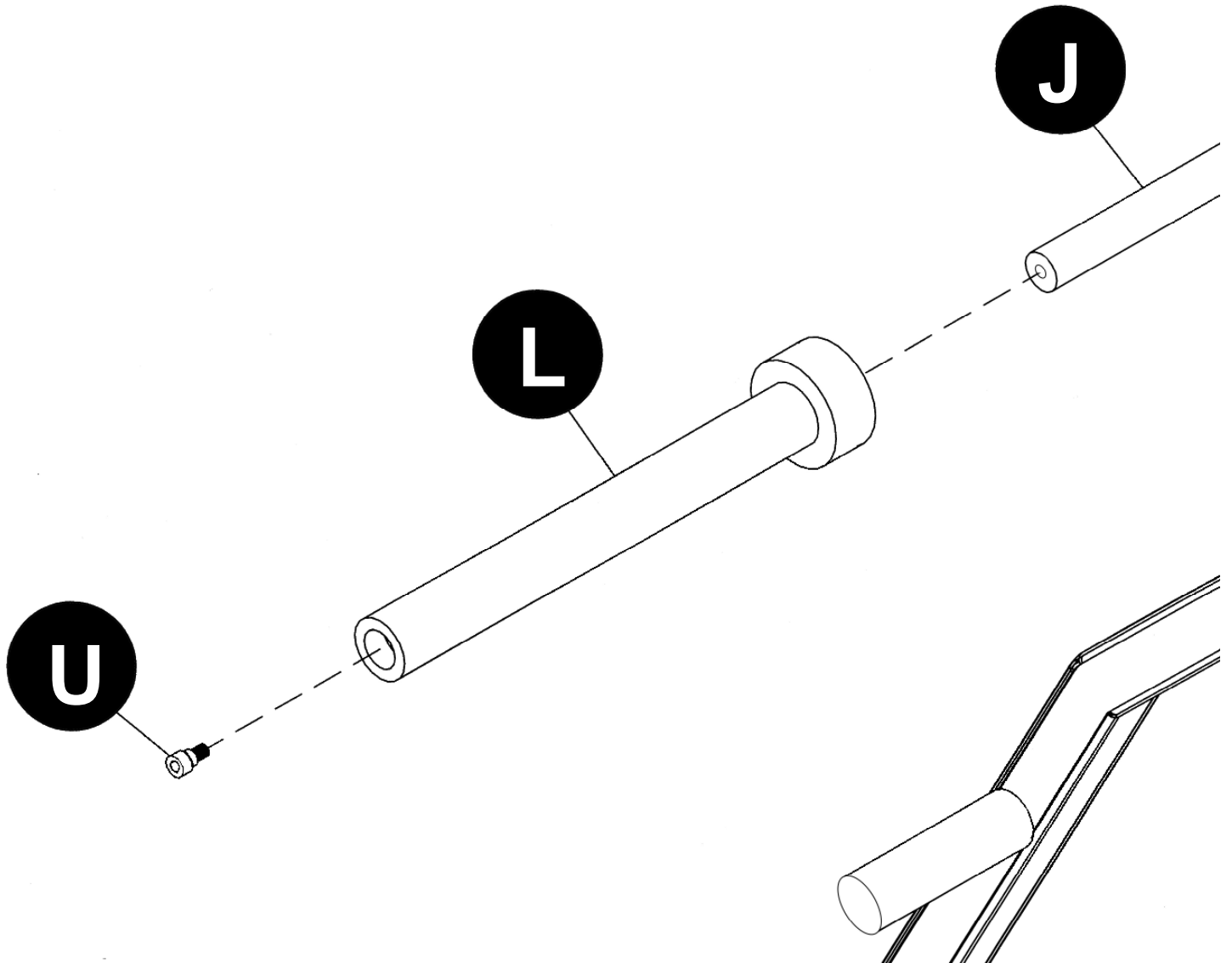

INSTALL WEIGHT SLEEVE (L) WITH WEIGHT SLEEVE BOLT (U) ONTO SMITH BAR (J) AND TIGHTEN WITH SUPPLIED HEX WRENCH. REPEAT FOR OPPOSITE SIDE.

TOP FRAME INSTALLATION

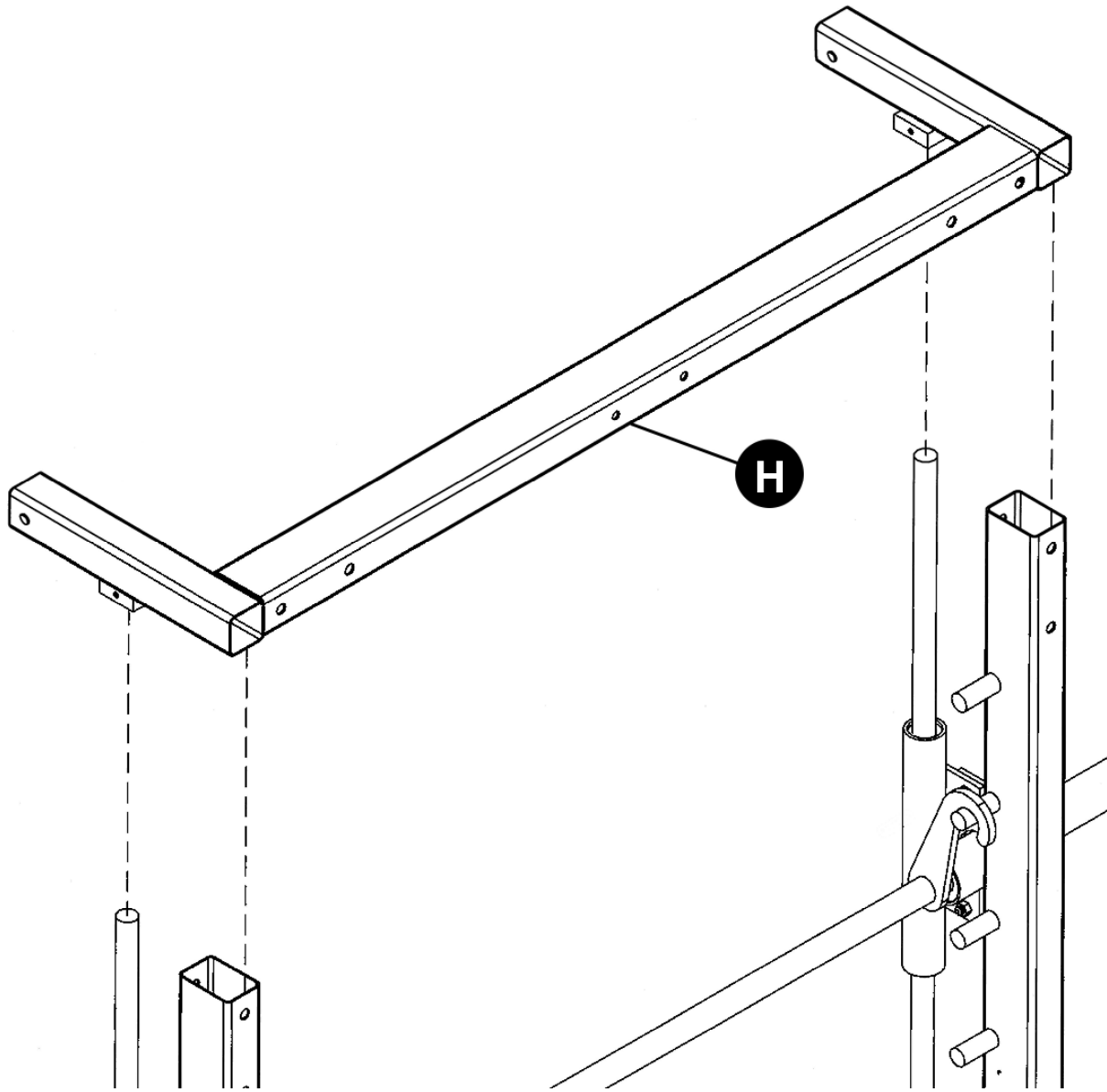

INSTALL THE TOP FRAME (H) ONTO THE UPRIGHTS AND GUIDE RODS.

TOP FRAME INSTALLATION

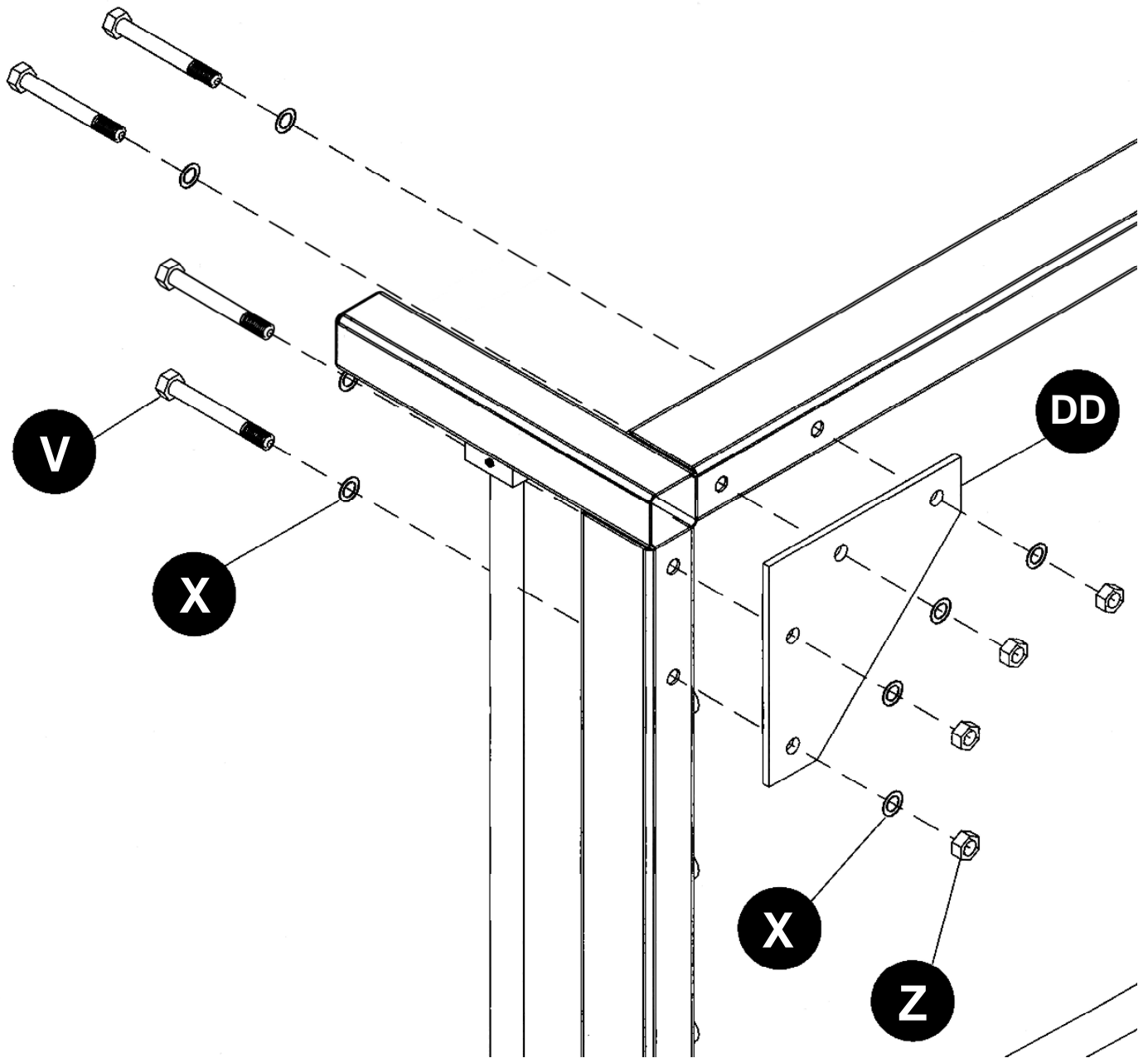

ATTACH THE TOP FRAME TO THE UPRIGHTS USING THE M12 x 90MM BOLTS (V), M12 WASHERS (X), CORNER FLANGES (DD), AND M12 LOCKNUTS (Z). REPEAT FOR OPPOSITE SIDE.

TOP FRAME INSTALLATION

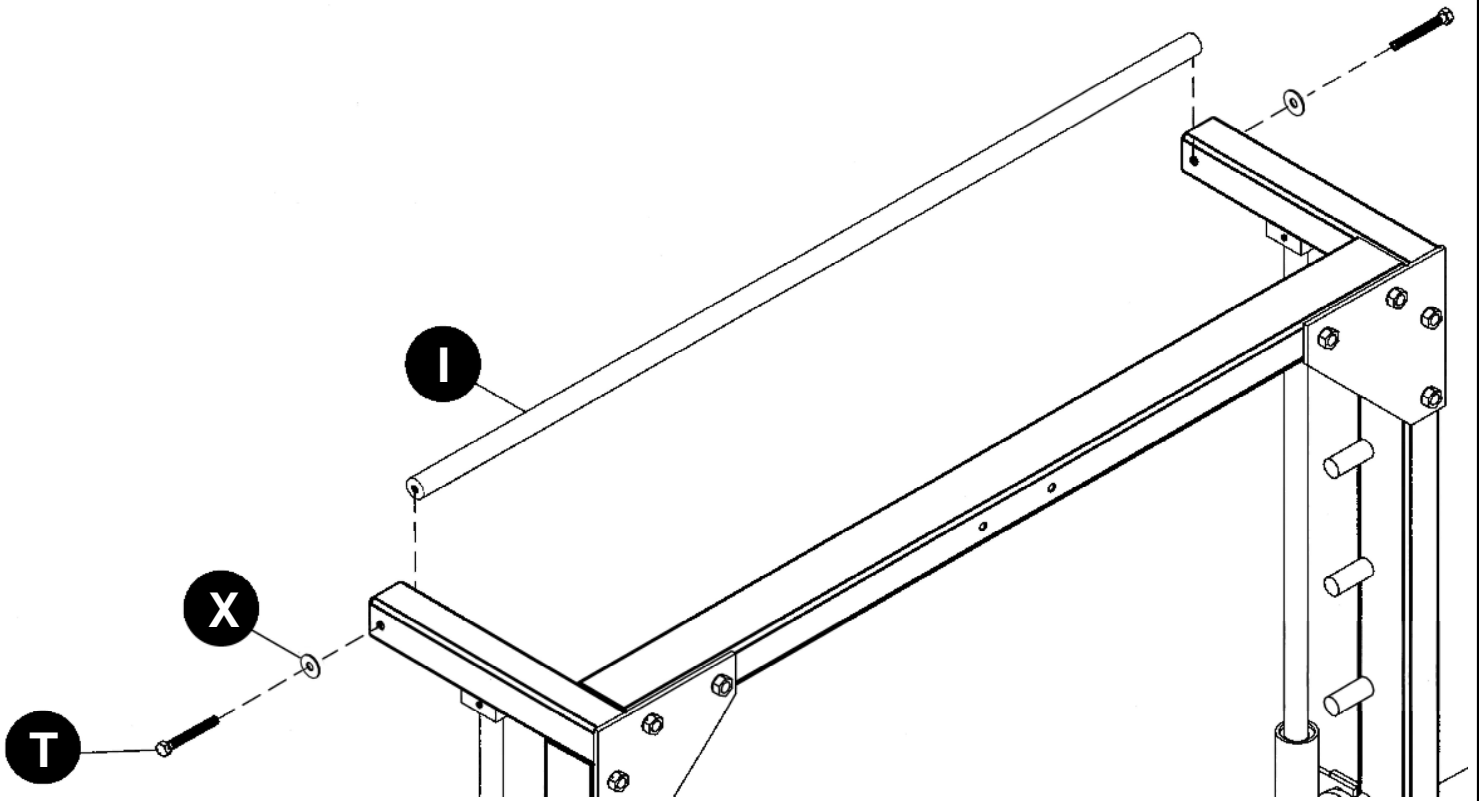

ATTACH THE PULL-UP BAR (I) TO THE TOP FRAME USING THE PULL-UP BAR BOLTS (T), AND M12 WASHERS (X).

MAKE SURE ALL THE BOLTS ARE TIGHT BEFORE USING. CHECK THEM PERIODICALLY TO ENSURE THE BOLTS STAY TIGHT. HAVE A GOOD WORKOUT!

GUIDE BAR ADJUSTMENT

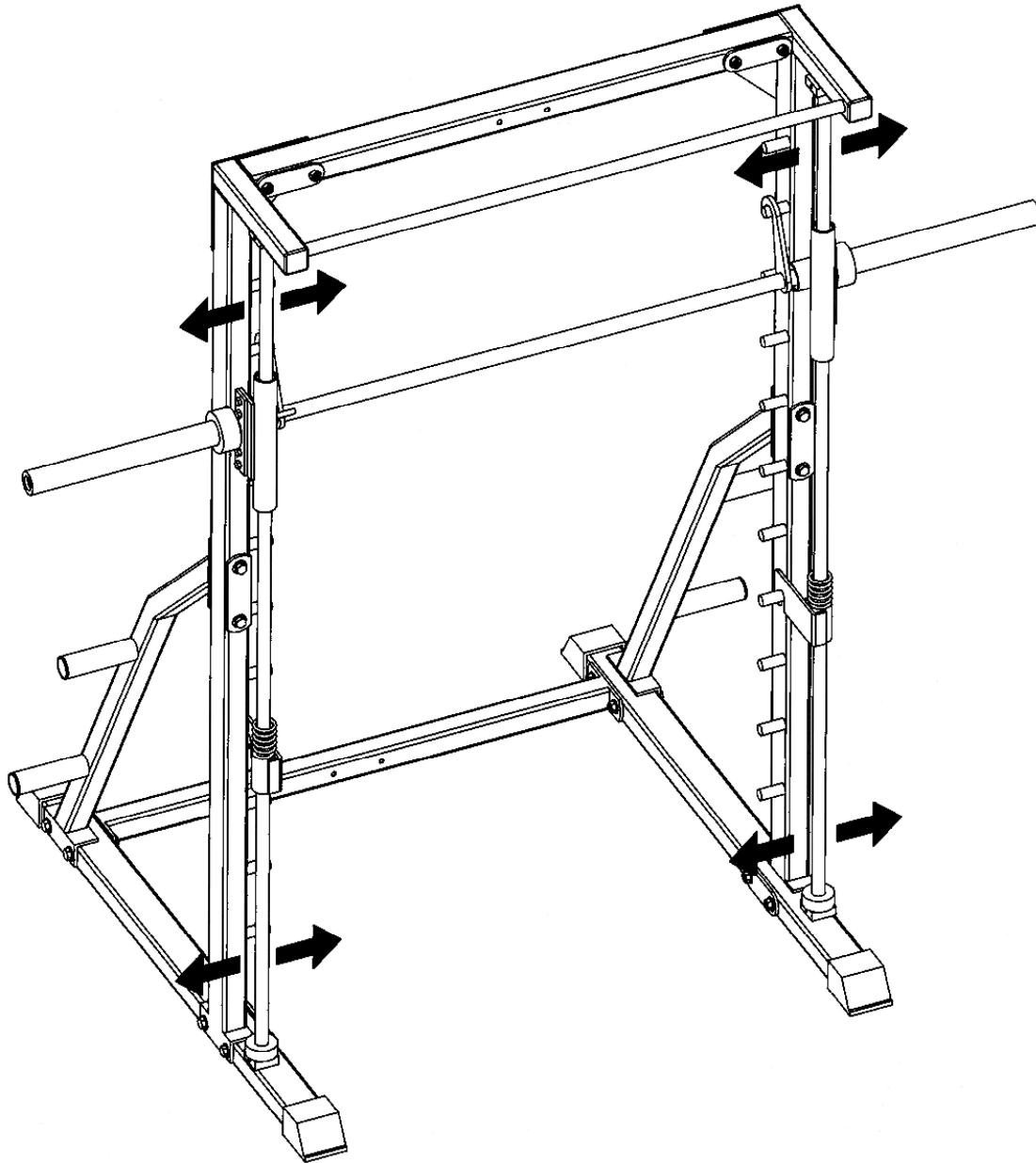

THE GUIDE BAR RETAINERS ARE SLOTTED TO ALLOW FOR ADJUSTMENT. USING THE SUPPLIED HEX WRENCH, TIGHTEN THE SET SCREWS ON BOTH SIDES OF THE BOTTOM RETAINER. HOLD A LEVEL AGAINST THE GUIDE ROD TO ENSURE IT IS LEVEL. IF NECESSARY ADJUST THE SET SCREWS ON THE UPPER RETAINER. REPEAT FOR OPPOSITE SIDE. (***ADJUSTING THE DISTANCE BETWEEN THE GUIDE RODS IS NOT NECESSARY AS THE SMITH BAR HAS A FLOATING SYSTEM TO ALLOW FOR VARIANCES***)

You have completed assembly of the DF4900 Smith Machine. Please refer to the assembly manuals of the DF830 Lat Attachment and DF835 Weight Stack attachment to complete full assembly. Please assemble the DF830 and then the DF835.

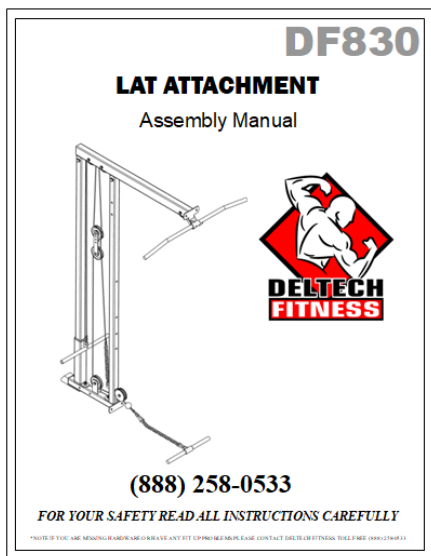

SAFETY NOTICE

WARNING: THE USER OF THIS WEIGHT EQUIPMENT ASSUMES THE POSSIBILITY OF INJURY BY EXERCISING ON THIS EQUIPMENT. THE POSSIBILITY OF RISK CAN BE REDUCED BY ALWAYS FOLLOWING THESE SIMPLE RULES:

- 1) BEFORE BEGINNING ANY EXERCISE PROGRAM, CONSULT YOUR DOCTOR FOR A COMPLETE PHYSICAL EXAMINATION AND SUGGESTED EXERCISE PROGRAM SPECIFIC FOR YOU.
- 2) STRETCH BEFORE AND AFTER THE EXERCISE PROGRAM, PROPER STRETCHING WILL PREPARE YOUR JOINTS AND MUSCLES FOR EXERCISE AND HELP AVOID INJURIES.
- 3) IF AT ANY TIME YOU SHOULD FEEL FAINT OR DIZZY, NAUSEOUS OR EXPERIENCE ANY OTHER ABNORMAL SYMPTOMS OR DISCOMFORT, DISCONTINUE USE AND CONSULT YOUR DOCTOR.
- 4) DO NOT USE THIS EQUIPMENT WITHOUT QUALIFIED SUPERVISION AND PROPER TRAINING NEVER WORK OUT ALONE ALWAYS HAVE A PARTNER.
- 5) SECURELY TIGHTEN ALL BOLTS AND REGULARLY CHECK TO ENSURE ALL BOLTS HAVE NOT LOOSEENED.
- 6) WEAR GOOD RUBBER SOLE SHOES ONLY DO NOT USE BARE FOOTED OR WITH SOCKS ONLY.
- 7) DO NOT WEAR LOOSE CLOTHES SUCH AS ROBES, GOWNS, PANTS, LONG SHIRTS OR JEWELRY WHICH COULD BECOME ENTANGLED IN MOVING PARTS.
- 8) DO NOT STAND OR KNEEL ON SEAT ALWAYS SIT OR LAY SQUARELY CENTERED.
- 9) KEEP HEAD, LIMBS AND BODY PARTS CLEAR OF MOVING PARTS AND WEIGHT PLATES.
- 10) CHILDREN SHOULD NOT USE EXERCISE EQUIPMENT WITHOUT SUPERVISION BECAUSE OF POSSIBILITY OF INJURY FROM IMPROPER USAGE. THIS EQUIPMENT IS INTENDED FOR HOME USE ONLY.
- 11) REPLACEMENT OR WORN OR DEFECTIVE PARTS MUST BE REPLACE WITH FACTORY AUTHORIZED PARTS. IF OTHER THAN FACTORY AUTHORIZED PARTS OR ASSESSORS ARE USED ALL WARRANTIES AND LIABILITIES BECOME VOID.

USE INSTRUCTIONS

- 1) SET THE SPOTTERS (9) TO THE DESIRED HEIGHT FOR A SAFE WORK OUT.
- 2) RAISE THE BAR AND ROTATE IT OUT UNTIL THE HOOK CLEARS THE PEGS.
- 3) DO EXERCISES AS DESIRED.
- 4) WHEN FINISHED WITH THE SET, ROTATE THE BAR BACK AND SET ON PEGS. MAKE SURE THE BAR IS SECURE BEFORE LETTING GO.
- 5) IF YOU DO INLINC PRESS EXERCISES, LIFT TOWARD THE BACK OF THE MACHINE OR PUT AT LEAST 90 LBS. ON THE WEIGHT HOLDERS TO AVOID A POSSIBLE TIPPING HAZARD.
- 6) WHEN DOING CHIN-UPS, LOWER THE WEIGHT BAR SO THE MACHINE IS NOT TOP HEAVY.