

DF4500LS

POWER RACK WITH LAT ATTACHMENT & 200 LB. WEIGHT STACK

Assembly Manual

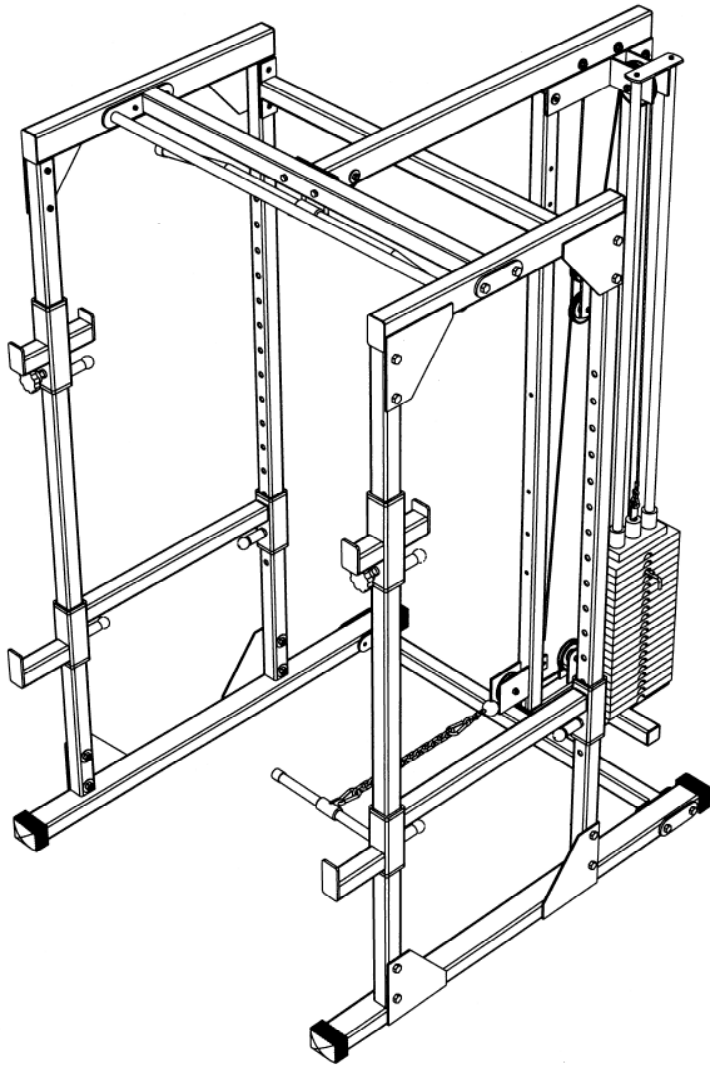

The DF4500LS consists of the DF4500 Power Rack, the DF830 Lat Attachment, and the DF835 Weight Stack Attachment

(888) 258-0533

FOR YOUR SAFETY READ ALL INSTRUCTIONS CAREFULLY

*NOTE IF YOU ARE MISSING HARDWARE OR HAVE ANY FIT UP PROBLEMS PLEASE CONTACT DELTECH FITNESS TOLL FREE (888) 258-0533

DF4500 BOX CONTENTS

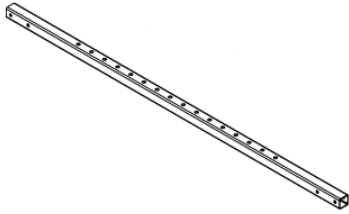

A
UPRIGHT POST
QTY 4

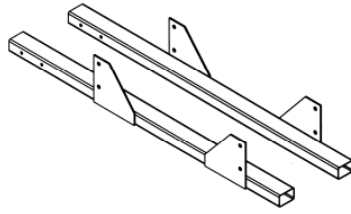

B
LEFT & RIGHT
BOTTOM FRAME
SUPPORTS
QTY 1 EACH

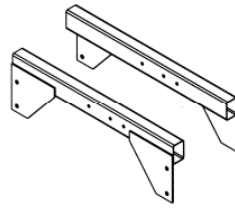

C
LEFT & RIGHT
TOP FRAME
SUPPORTS
QTY 1 EACH

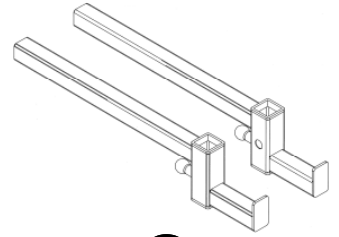

D
LH & RH
FRONT SPOTTER BAR
QTY 1 EACH

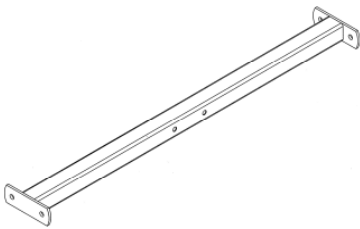

E
LOWER CROSSMEMBER
QTY 1

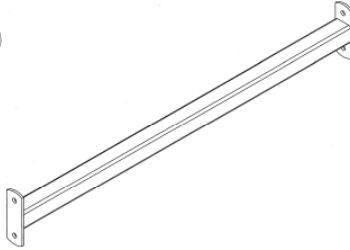

F
UPPER CROSSMEMBER
QTY 1

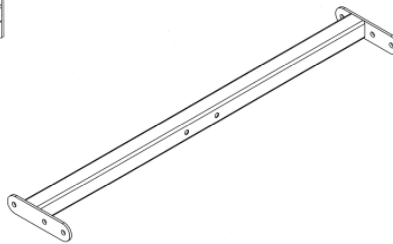

G
CHIN-UP BAR ASSY
QTY 1

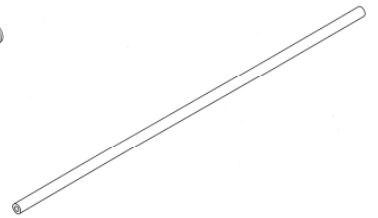

H
CHIN-UP BAR
QTY 1

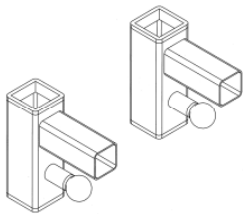

I
LH & RH
REAR SPOTTER BAR
QTY 1 EACH

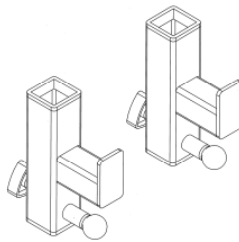

J
LH & RH
REAR BAR CATCH
QTY 1 EACH

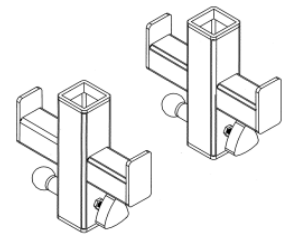

K
LH & RH
FRONT BAR CATCH
QTY 1 EACH

DF4500 HARDWARE

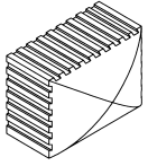

L
RUBBER SHOE
QTY 4



M
RECTANGULAR CAP
QTY 4

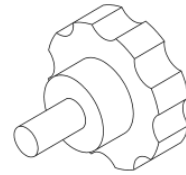

N
KNOB
QTY 4

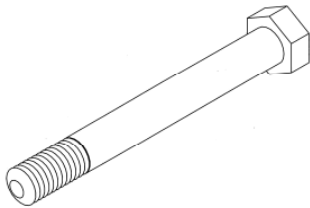

O
M12 x 115MM BOLT
QTY 4

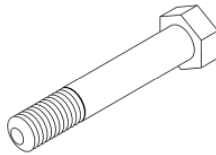

P
M12 x 76MM BOLT
QTY 22



Q
M12 WASHER
QTY 52



S
M12 LOCKNUT
QTY 26

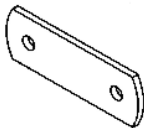

U
MOUNTING FLANGE
QTY 10

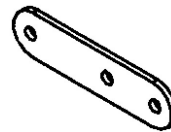

V
MOUNTING FLANGE
QTY 2

FOR YOUR SAFETY READ ALL INSTRUCTIONS CAREFULLY

*NOTE IF YOU ARE MISSING HARDWARE OR HAVE ANY FIT UP PROBLEMS PLEASE CONTACT DELTECH FITNESS TOLL FREE (888) 258-0533

FRAME ASSEMBLY

(NOTE: THE NUTS USED ON THIS RACK ARE LOCK NUTS, THIS MEANS YOU MUST TIGHTEN THEM DOWN PAST THE PLASTIC INSERT.)

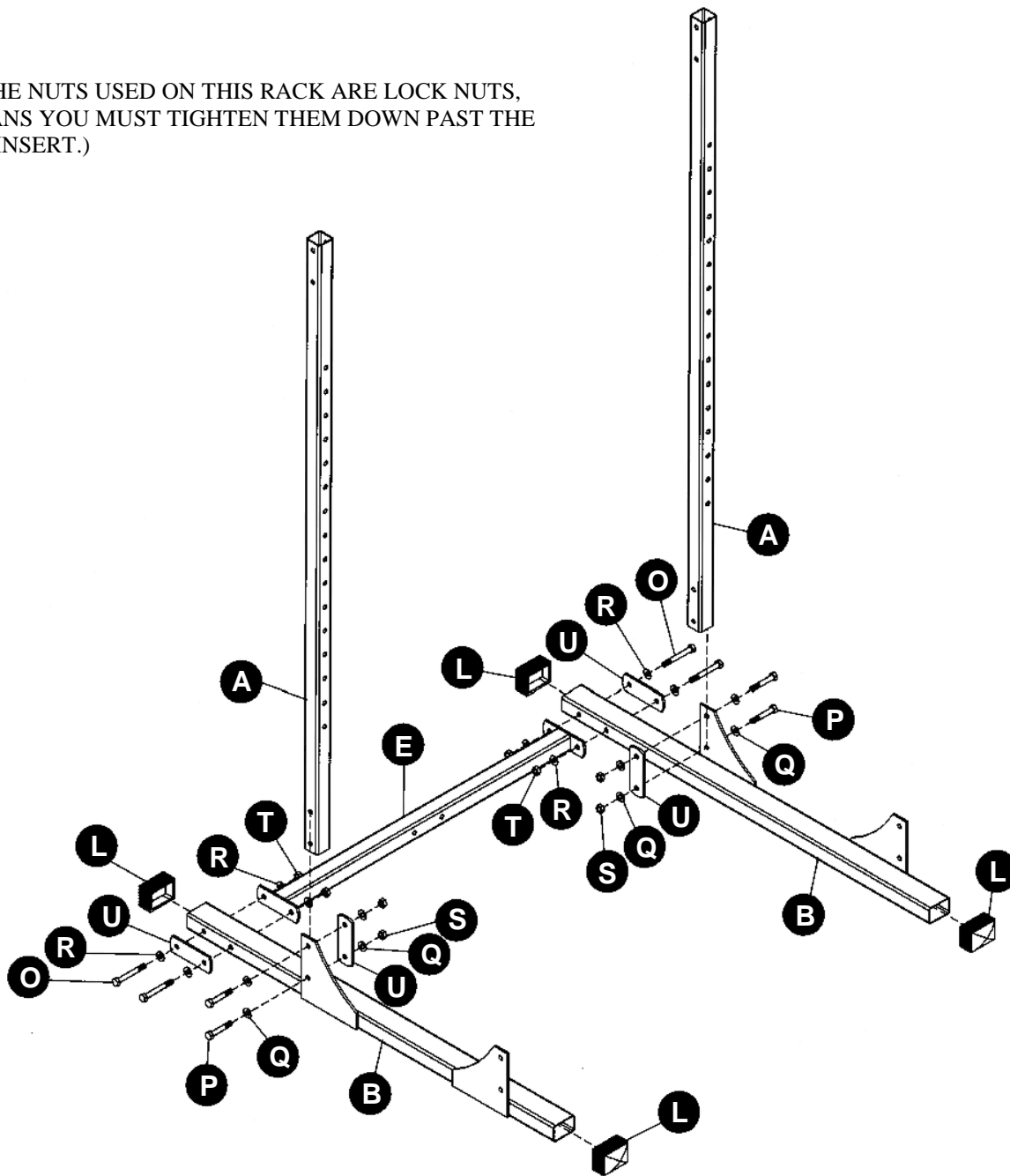

TOOLS REQUIRED FOR ASSEMBLY

ADJUSTABLE WRENCHES OR METRIC SOCKET SET

INSTALL REAR UPRIGHTS (A) ONTO THE LEFT & RIGHT BOTTOM FRAME SUPPORTS (B) USING THE M12 x 76MM BOLTS (P), MOUNTING FLANGES (U), M12 WASHERS (Q), AND M12 LOCK NUTS (S). ATTACH TO THE REAR CROSS MEMBER (E) USING THE M10 x 115MM BOLTS (O), MOUNTING FLANGES (U), M10 WASHERS (R), AND M10 LOCK NUTS (T).

NEXT SLIDE ON THE RUBBER BOOTS (L) TO THE LEFT & RIGHT BOTTOM FRAME SUPPORTS (B) .

SPOTTER & BAR CATCH ASSEMBLY

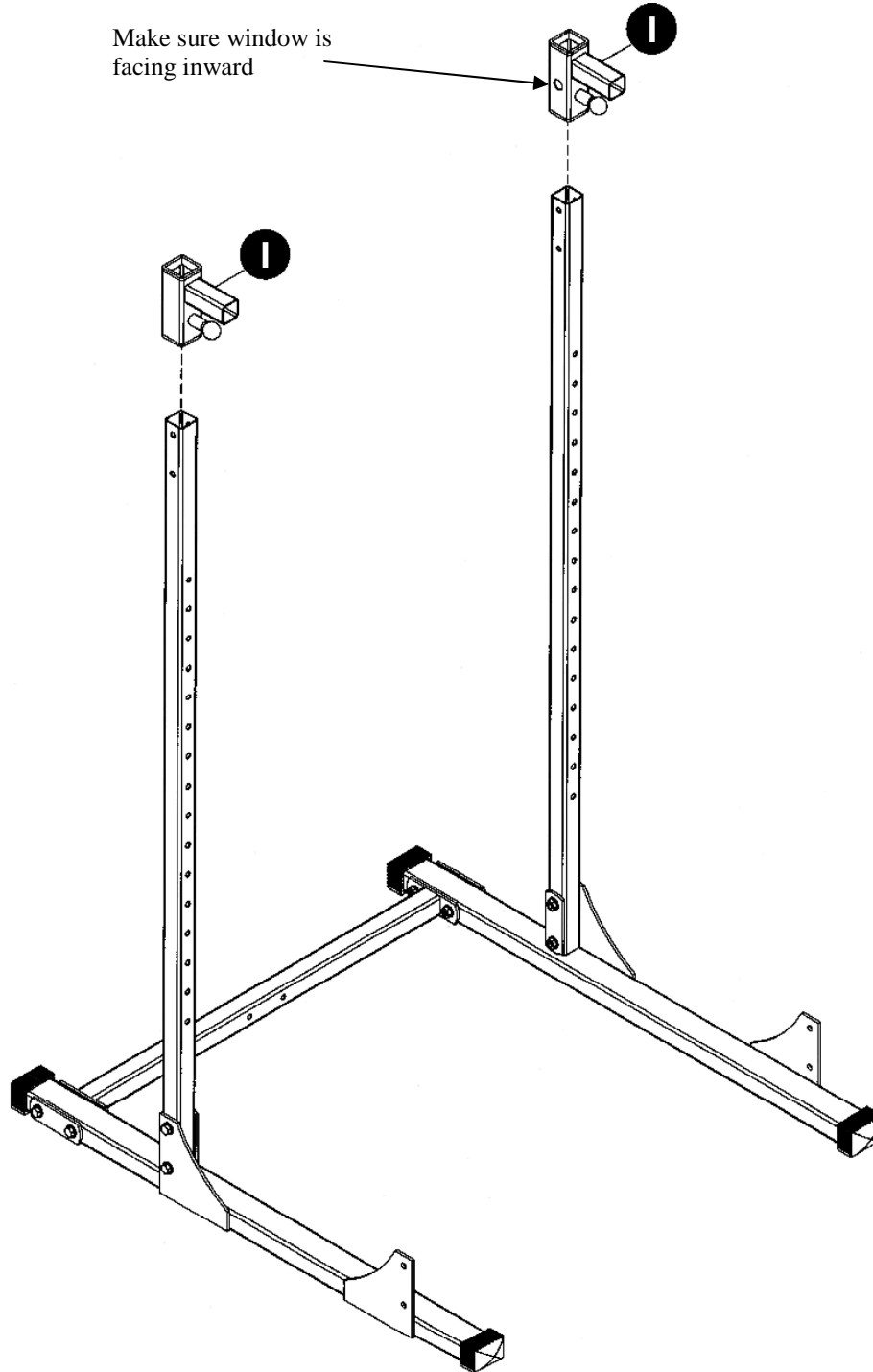

INSTALL THE REAR SPOTTER BARS (I) ONTO THE REAR UPRIGHTS. MAKE SURE THAT THE CIRCULAR WINDOW IS FACING INWARD. LOWER TO THE HIGHEST HOLE POSITION AND LOCK INTO PLACE WITH THE LOCK PIN.

SPOTTER BAR INSTALLATION

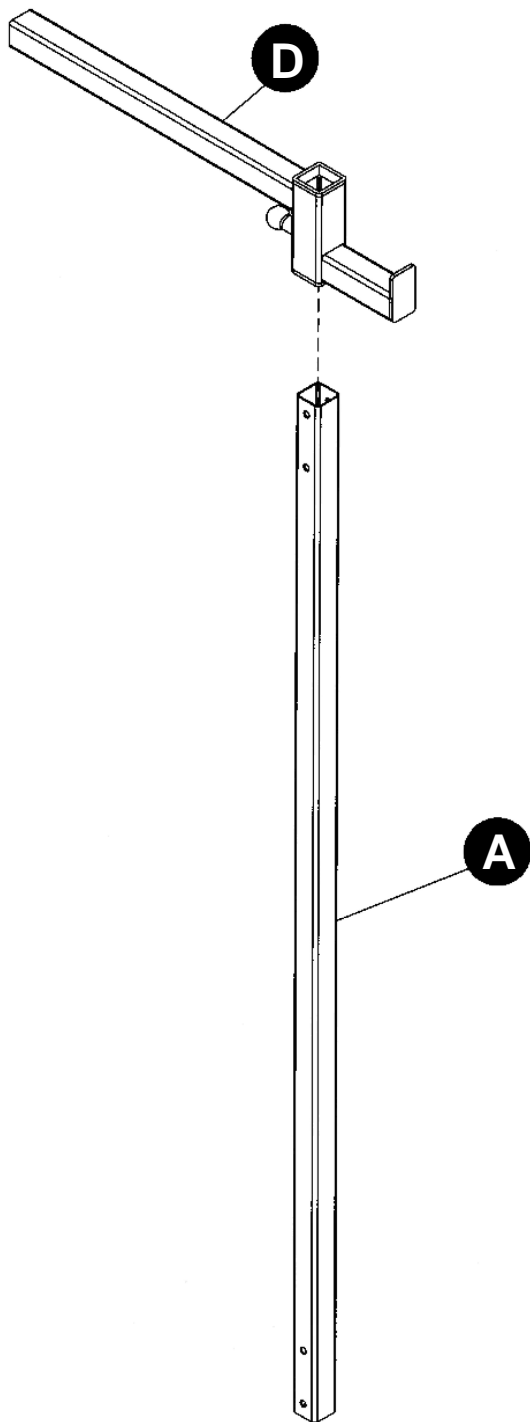

INSTALL THE FRONT SPOTTER BAR (D) ON TO THE FRONT UPRIGHT (A). LOWER TO THE HIGHEST HOLE POSITION AND LOCK INTO PLACE WITH THE LOCK PIN. REPEAT FOR THE OPPOSITE SIDE.

SPOTTER BAR INSTALLATION

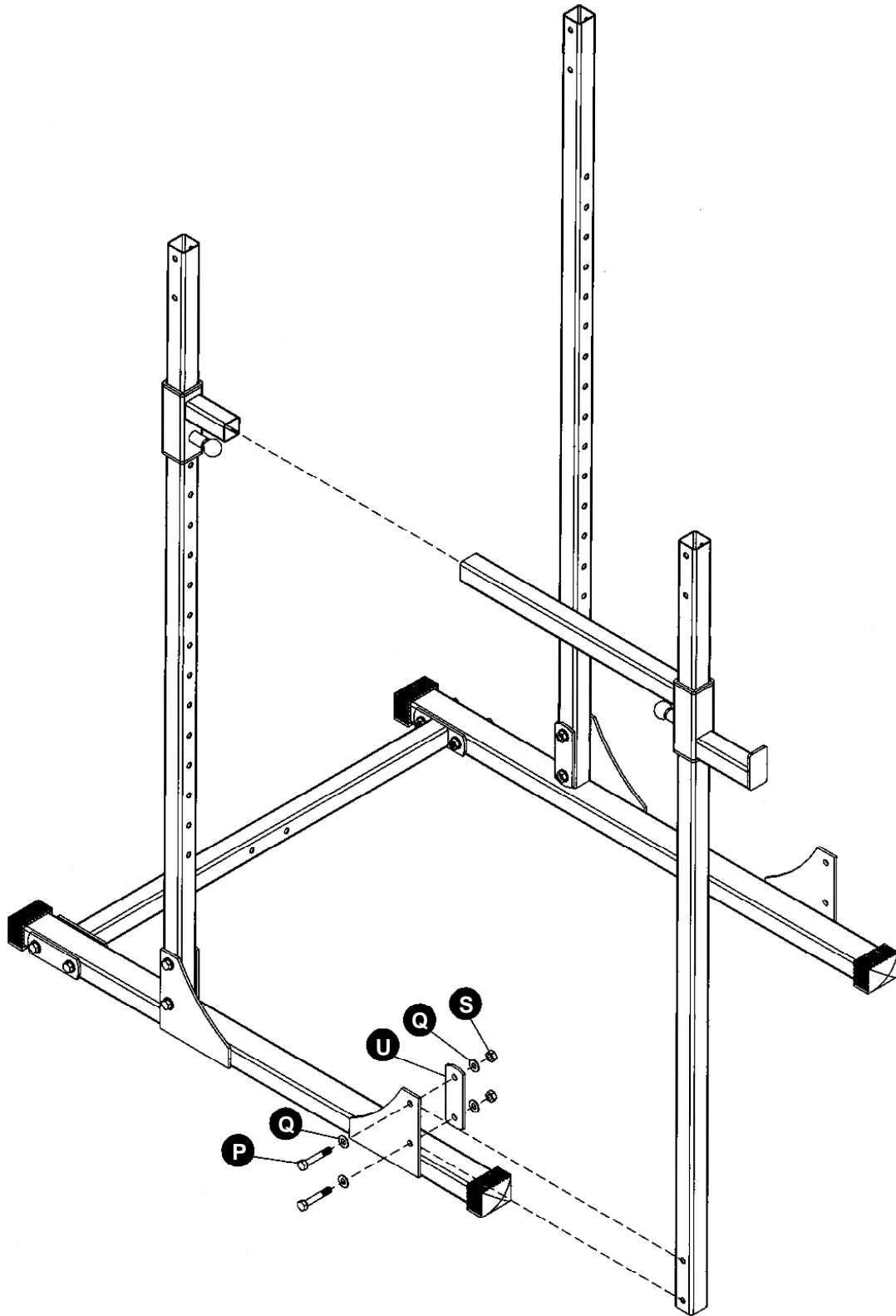

SLIDE THE FRONT SPOTTER BAR INTO THE REAR SPOTTER. INSTALL THE FRONT UPRIGHT TO THE BOTTOM FRAME USING THE M12 x 75MM BOLTS (P), M12 WASHERS (Q), MOUNTING FLANGE (U), AND M12 NUTS (S). REPEAT FOR OPPOSITE SIDE.

BAR CATCH INSTALLATION

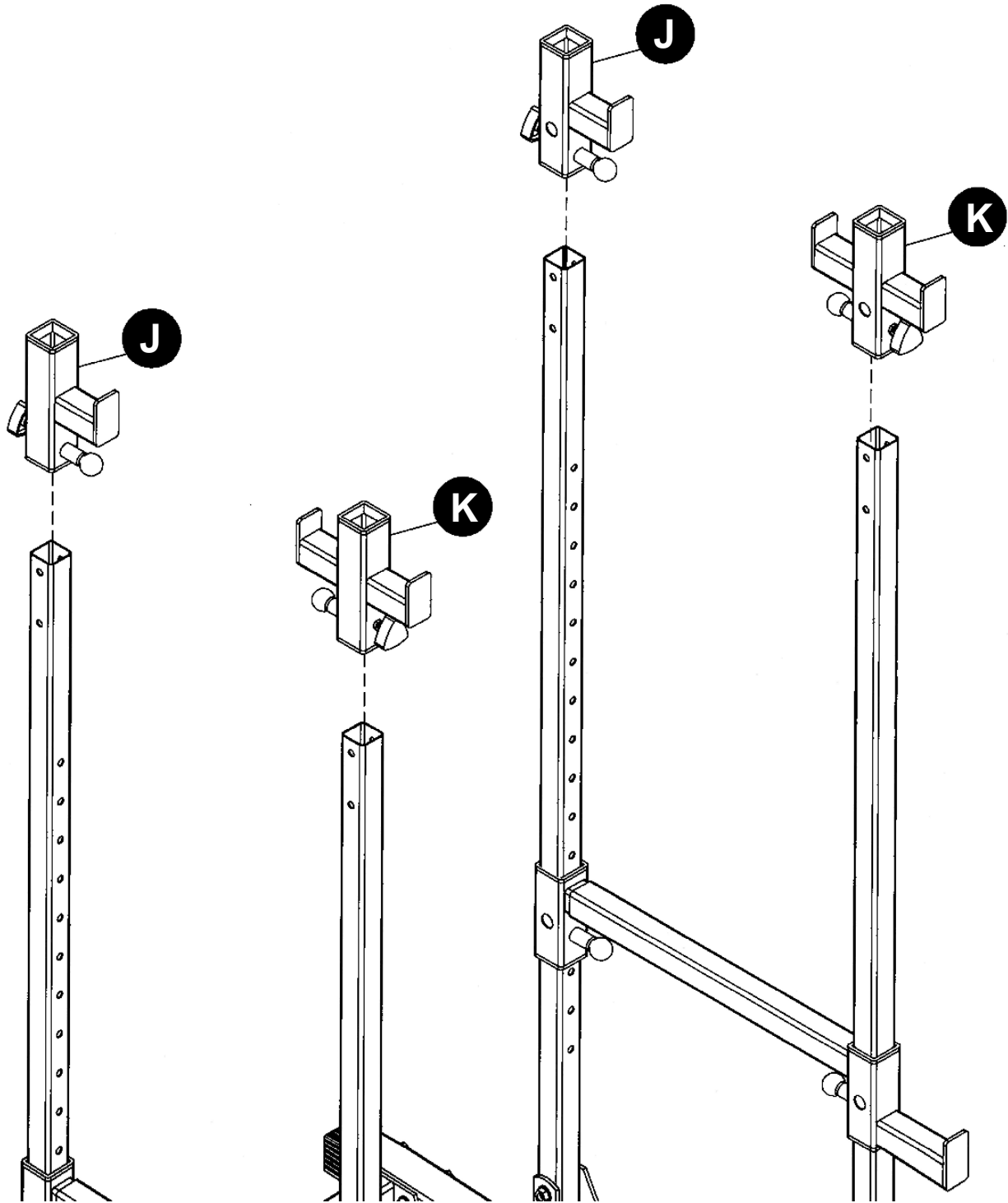

INSTALL THE REAR BAR CATCHES (J), AND LH & RH FRONT BAR CATCHES (K) AND LOCK INTO PLACE WITH PULL-PINS.

FRAME ASSEMBLY

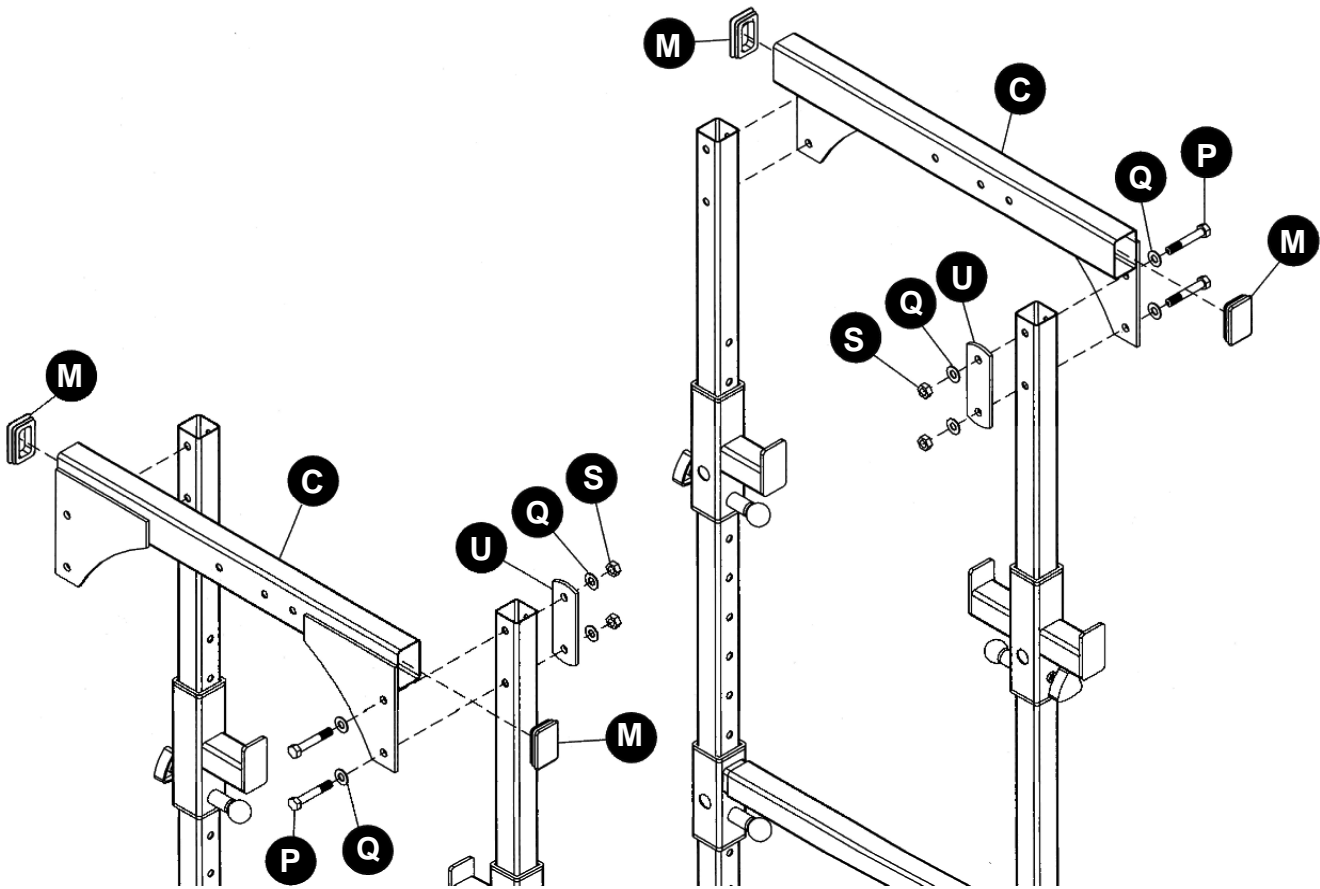

INSTALL THE LEFT AND RIGHT TOP FRAME SUPPORTS (C), TO THE FRONT UPRIGHTS USING THE M12 x 75MM BOLTS (P), M12 WASHERS (Q), MOUNTING FLANGES (U), AND M12 NUTS (S). DO NOT BOLT TO THE REAR UPRIGHTS AT THIS TIME.

INSERT THE RECTANGULAR CAPS (M) INTO THE ENDS OF THE TOP FRAME SUPPORTS (C).

FRAME ASSEMBLY

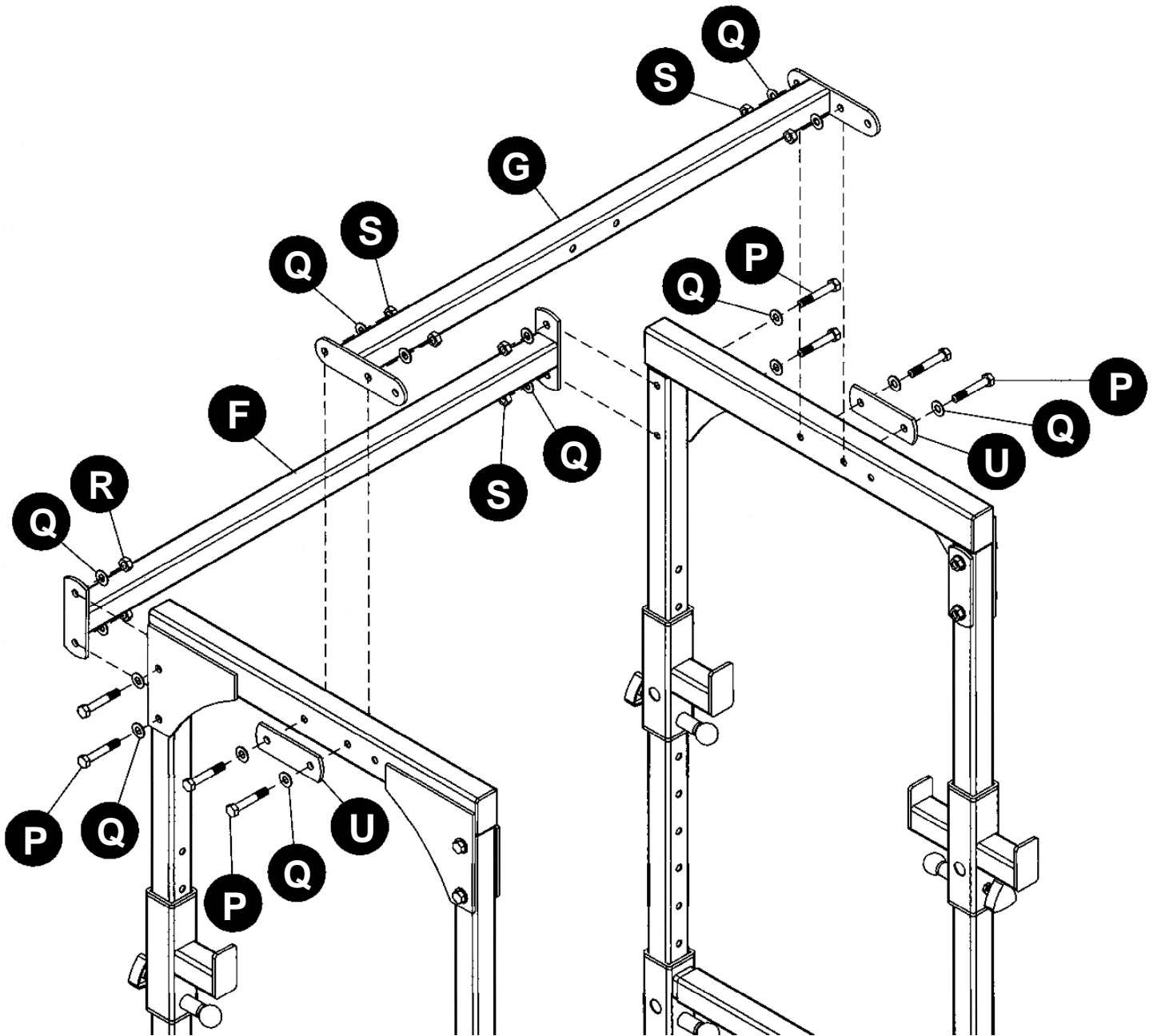

INSTALL THE CHIN-UP BAR ASSEMBLY (G), BETWEEN THE TOP FRAME SUPPORTS USING THE M12 x 75MM BOLTS (P), M12 WASHERS (Q), MOUNTING FLANGES (U), AND M12 NUTS (S).

INSTALL THE UPPER CROSSMEMBER (F), BETWEEN THE REAR UPRIGHTS USING THE M12 x 75MM BOLTS (P), M12 WASHERS (Q), AND M12 NUTS (S).

CHIN-UP BAR ASSEMBLY

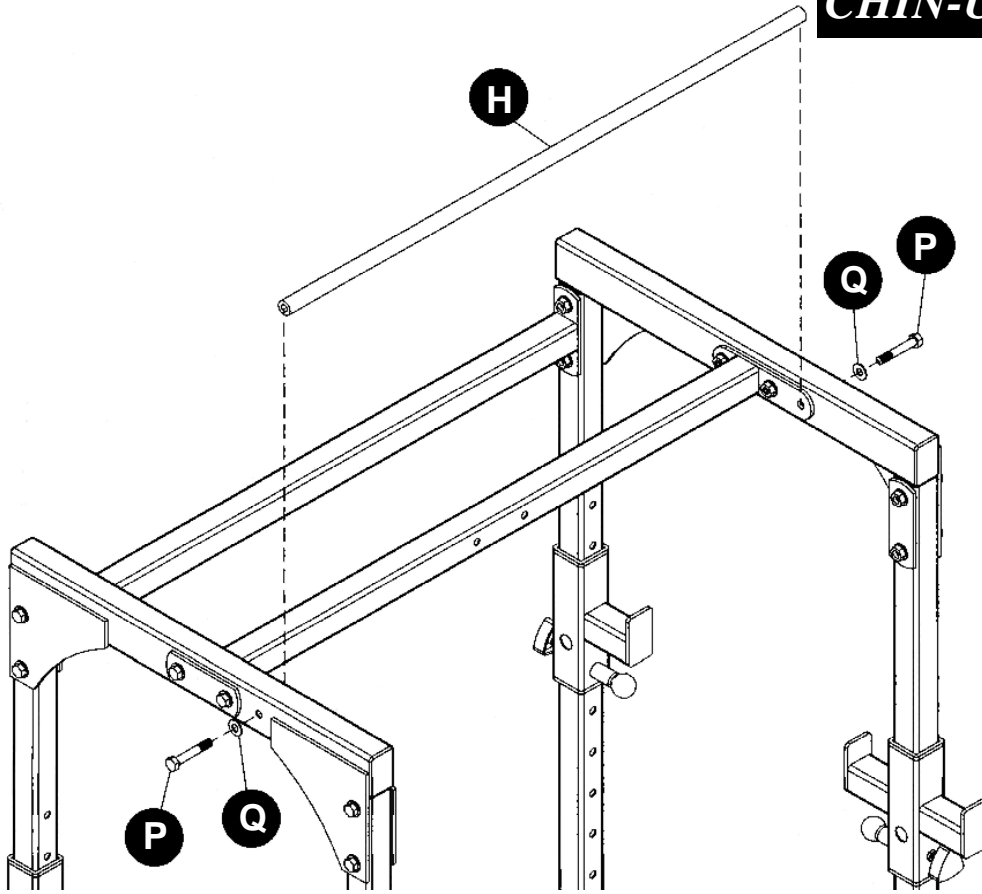

INSTALL THE CHIN-UP BAR (H) INTO THE CHIN-UP BAR ASSEMBLY USING THE M12 x 75MM BOLTS (P), AND M12 WASHERS (Q).

ADJUSTING THE WEIGHT HOLDERS:

RAISE AND LOWER THE WEIGHT HOLDERS BY TURNING THE KNOB TO LOOSEN, THEN USE THE PULL PIN TO MAKE THE HEIGHT ADJUSTMENT. MAKE SURE THE PULL PIN IS SECURE IN THE ADJUSTMENT HOLE THEN TURN THE KNOB TO TIGHTEN BEFORE USE.

* NOTE MAKE SURE THE WEIGHT HOLDERS ARE THE SAME HEIGHT ON BOTH SIDES BEFORE USE.

ADJUSTING THE SPOTTER BARS:

RAISE AND LOWER THE SPOTTER BARS BY USING THE PULL PINS TO MAKE THE HEIGHT ADJUSTMENT. MAKE SURE THE PULL PIN IS SECURE IN THE ADJUSTMENT HOLE. .

* NOTE MAKE SURE THE SPOTTER BARS ARE THE SAME HEIGHT ON EACH SIDE BEFORE USE.

SAFETY NOTICE

WARNING: THE USER OF THIS WEIGHT EQUIPMENT ASSUMES THE POSSIBILITY OF INJURY BY EXERCISING ON THIS EQUIPMENT. THE POSSIBILITY OF RISK CAN BE REDUCED BY ALWAYS FOLLOWING THESE SIMPLE RULES:

- 1) BEFORE BEGINNING ANY EXERCISE PROGRAM, CONSULT YOUR DOCTOR FOR A COMPLETE PHYSICAL EXAMINATION AND SUGGESTED EXERCISE PROGRAM SPECIFIC FOR YOU.
- 2) STRETCH BEFORE AND AFTER THE EXERCISE PROGRAM. PROPER STRETCHING WILL PREPARE YOUR JOINTS AND MUSCLES FOR EXERCISE AND HELP AVOID INJURIES.
- 3) IF AT ANY TIME YOU SHOULD FEEL FAINT OR DIZZY, NAUSEOUS OR EXPERIENCE ANY OTHER ABNORMAL SYMPTOMS OR DISCOMFORT DISCONTINUE USE AND CONSULT YOUR DOCTOR.
- 4) DO NOT USE THIS EQUIPMENT WITHOUT QUALIFIED SUPERVISION AND PROPER TRAINING. NEVER WORK OUT ALONE- ALWAYS HAVE A PARTNER.
- 5) SECURELY TIGHTEN ALL BOLTS AND REGULARLY CHECK TO ENSURE ALL BOLTS HAVE NOT LOOSENED.
- 6) WEAR GOOD RUBBER SOLE SHOES ONLY. DO NOT USE BARE FOOTED OR WITH SOCKS ONLY.
- 7) DO NOT WEAR LOOSE CLOTHES SUCH AS ROBES, GOWNS, PANTS, LONG SHIRTS OR JEWELRY WHICH COULD BECOME ENTANGLED IN MOVING PARTS.
- 8) DO NOT STAND OR KNEEL ON SEAT. ALWAYS SIT OR LAY SQUARELY CENTERED.
- 9) KEEP HEAD, LIMBS AND BODY PARTS CLEAR OF MOVING PARTS AND WEIGHT PLATES.
- 10) CHILDREN SHOULD NOT USE EXERCISE EQUIPMENT WITHOUT SUPERVISION BECAUSE OF POSSIBILITY OF INJURY FROM IMPROPER USAGE. THIS EQUIPMENT IS INTENDED FOR HOME USE ONLY.
- 11) REPLACEMENT OF WORN OR DEFECTIVE PARTS MUST BE WITH FACTORY AUTHORIZED PARTS. IF OTHER THAN FACTORY AUTHORIZED PARTS OR ASSESSORS ARE USED ALL WARRANTIES AND LIABILITIES BECOME VOID.

EXERCISES



SQUAT



TOE RAISE



SHRUG



FLAT BENCH PRESS

EXERCISES



INCLINE PRESS



DECLINE PRESS



MILITARY PRESS



CHIN-UP

You have completed assembly of the DF4500 Power Rack. Please refer to the assembly manuals of the DF830 Lat Attachment and DF835 Weight Stack attachment to complete full assembly. Please assemble the DF830 and then the DF835.

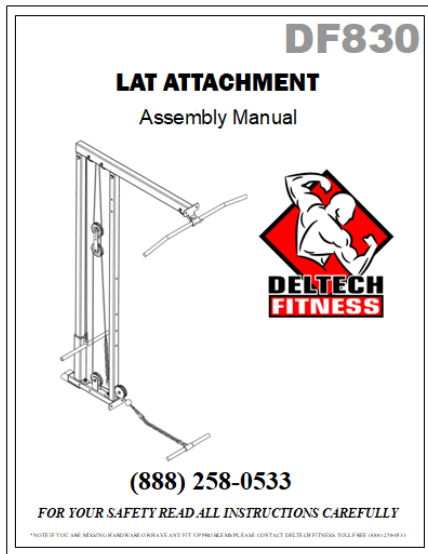

SAFETY NOTICE

WARNING: THE USER OF THIS WEIGHT EQUIPMENT ASSUMES THE POSSIBILITY OF INJURY BY EXERCISING ON THIS EQUIPMENT. THE POSSIBILITY OF RISK CAN BE REDUCED BY ALWAYS FOLLOWING THESE SIMPLE RULES:

- 1) BEFORE BEGINNING ANY EXERCISE PROGRAM, CONSULT YOUR DOCTOR FOR A COMPLETE PHYSICAL EXAMINATION AND SUGGESTED EXERCISE PROGRAM SPECIFIC FOR YOU.
- 2) STRETCH BEFORE AND AFTER THE EXERCISE PROGRAM, PROPER STRETCHING WILL PREPARE YOUR JOINTS AND MUSCLES FOR EXERCISE AND HELP AVOID INJURIES.
- 3) IF AT ANY TIME YOU SHOULD FEEL FAINT OR DIZZY, NAUSEOUS OR EXPERIENCE ANY OTHER ABNORMAL SYMPTOMS OR DISCOMFORT, DISCONTINUE USE AND CONSULT YOUR DOCTOR.
- 4) DO NOT USE THIS EQUIPMENT WITHOUT QUALIFIED SUPERVISION AND PROPER TRAINING NEVER WORK OUT ALONE ALWAYS HAVE A PARTNER.
- 5) SECURELY TIGHTEN ALL BOLTS AND REGULARLY CHECK TO ENSURE ALL BOLTS HAVE NOT LOOSENED.
- 6) WEAR GOOD RUBBER SOLE SHOES ONLY DO NOT USE BARE FOOTED OR WITH SOCKS ONLY.
- 7) DO NOT WEAR LOOSE CLOTHES SUCH AS ROBES, GOWNS, PANTS, LONG SHIRTS OR JEWELRY WHICH COULD BECOME ENTANGLED IN MOVING PARTS.
- 8) DO NOT STAND OR KNEEL ON SEAT ALWAYS SIT OR LAY SQUARELY CENTERED.
- 9) KEEP HEAD, LIMBS AND BODY PARTS CLEAR OF MOVING PARTS AND WEIGHT PLATES.
- 10) CHILDREN SHOULD NOT USE EXERCISE EQUIPMENT WITHOUT SUPERVISION BECAUSE OF POSSIBILITY OF INJURY FROM IMPROPER USAGE. THIS EQUIPMENT IS INTENDED FOR HOME USE ONLY.
- 11) REPLACEMENT OR WORN OR DEFECTIVE PARTS MUST BE REPLACED WITH FACTORY AUTHORIZED PARTS. IF OTHER THAN FACTORY AUTHORIZED PARTS OR ASSESSORS ARE USED ALL WARRANTIES AND LIABILITIES BECOME VOID.