

# *ASSEMBLY INSTRUCTIONS FOR THE DF4500 PRO POWER RACK*

---

750 LB WEIGHT CAPACITY

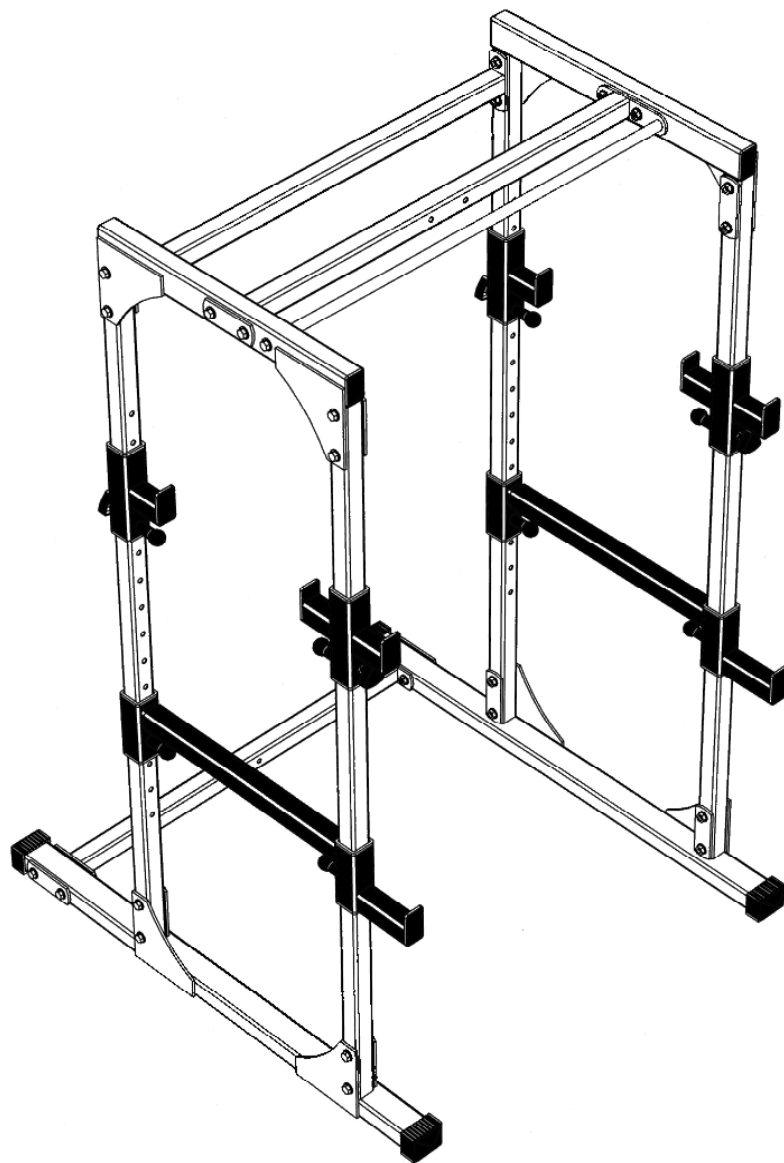

**(888) 258-0533**

***FOR YOUR SAFETY READ ALL INSTRUCTIONS CAREFULLY***

\*NOTE IF YOU ARE MISSING HARDWARE OR HAVE ANY FIT UP PROBLEMS PLEASE CONTACT DELTECH FITNESS TOLL FREE (888) 258-0533

# DF4500 BOX CONTENTS

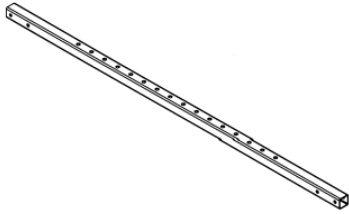

**A**

UPRIGHT POST  
QTY 4

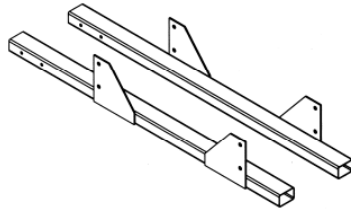

**B**

LEFT & RIGHT  
BOTTOM FRAME  
SUPPORTS  
QTY 1 EACH

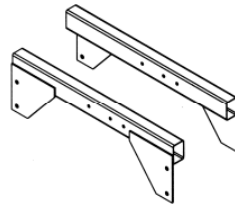

**C**

LEFT & RIGHT  
TOP FRAME  
SUPPORTS  
QTY 1 EACH

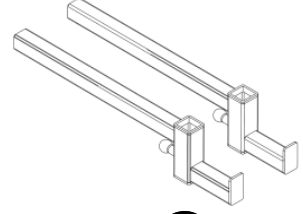

**D**

FRONT SPOTTER BARS  
QTY 2

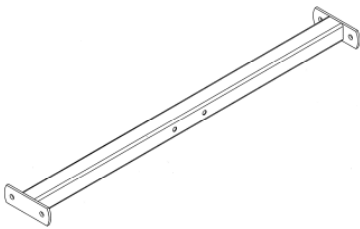

**E**

LOWER CROSSMEMBER  
QTY 1

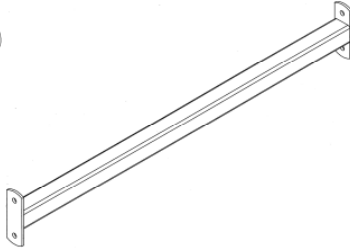

**F**

UPPER CROSSMEMBER  
QTY 1

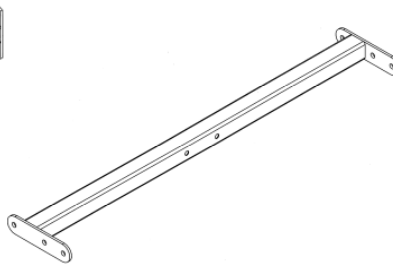

**G**

CHIN-UP BAR ASSY  
QTY 1

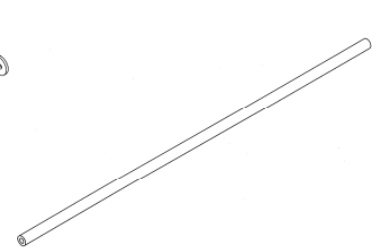

**H**

CHIN-UP BAR  
QTY 1

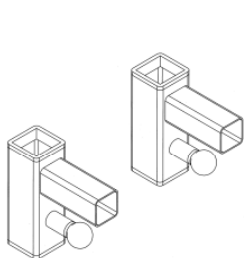

**I**

REAR SPOTTER BARS  
QTY 2

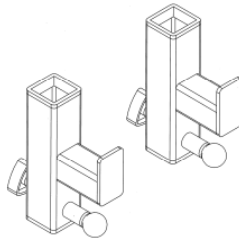

**J**

REAR BAR CATCHES  
QTY 2

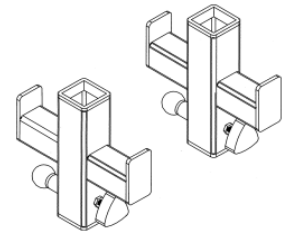

**K**

FRONT BAR CATCHES  
QTY 2

# ***DF4500 HARDWARE***

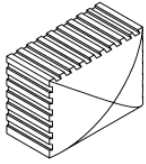

**L**

**RUBBER SHOE  
QTY 4**



**M**

**RECTANGULAR CAP  
QTY 4**

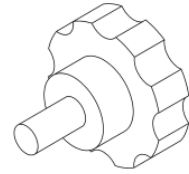

**N**

**KNOB  
QTY 4**

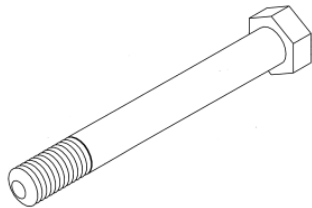

**O**

**M12 x 100MM BOLT  
QTY 4**

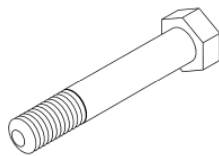

**P**

**M12 x 75MM BOLT  
QTY 22**



**Q**

**M12 WASHER  
QTY 50**

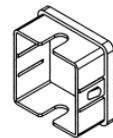

**R**

**REDUCER  
QTY 16**



**S**

**M12 LOCKNUT  
QTY 24**

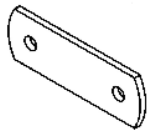

**U**

**MOUNTING FLANGE  
QTY 8**

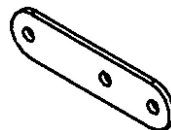

**V**

**MOUNTING FLANGE  
QTY 2**

***FOR YOUR SAFETY READ ALL INSTRUCTIONS CAREFULLY***

\*NOTE IF YOU ARE MISSING HARDWARE OR HAVE ANY FIT UP PROBLEMS PLEASE CONTACT DELTECH FITNESS TOLL FREE (888) 258-0533

## FRAME ASSEMBLY

(NOTE: THE NUTS USED ON THIS RACK ARE LOCK NUTS, THIS MEANS YOU MUST TIGHTEN THEM DOWN PAST THE PLASTIC INSERT.)

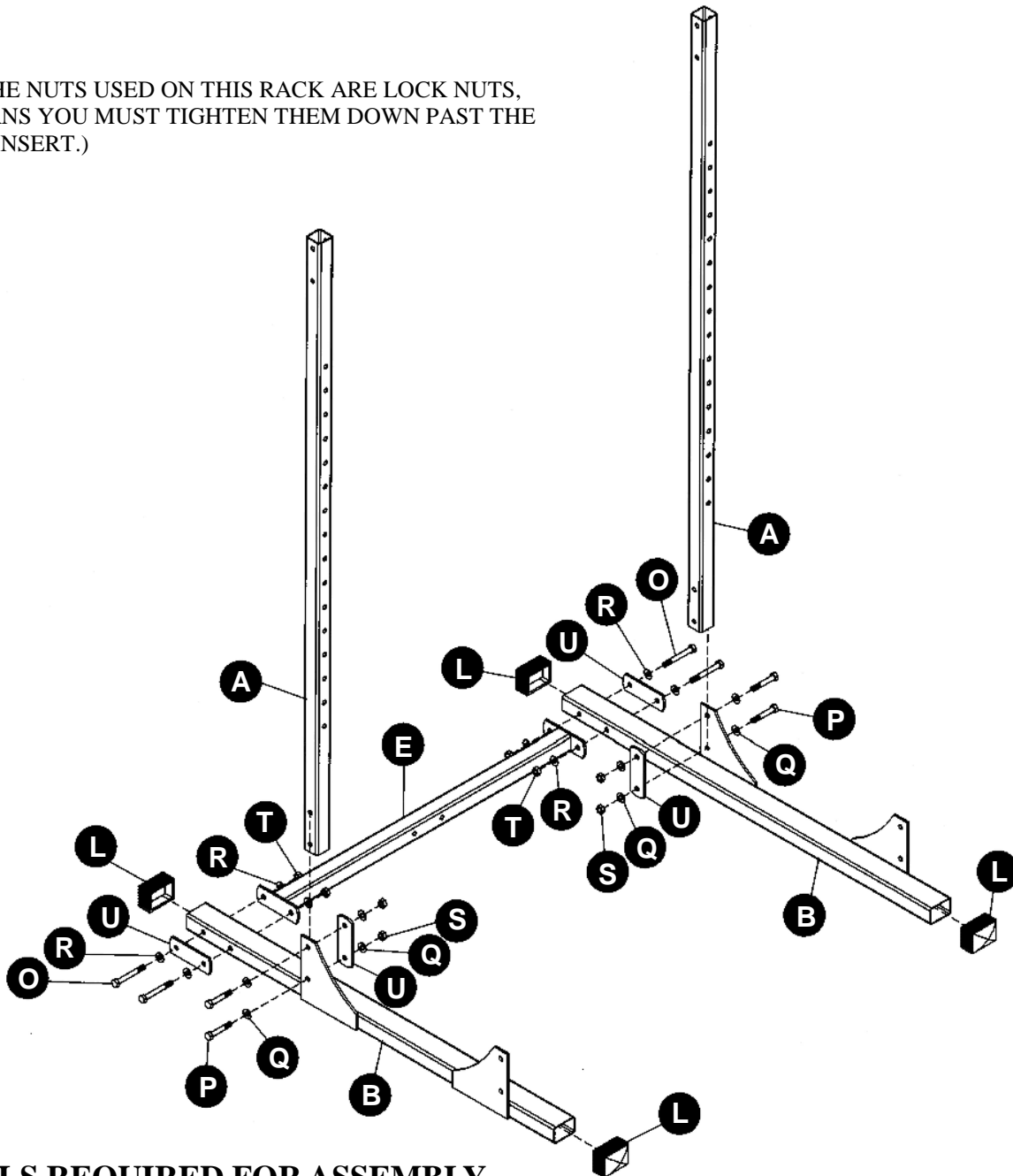

### TOOLS REQUIRED FOR ASSEMBLY

ADJUSTABLE WRENCHES OR METRIC SOCKET SET

ATTACH THE REAR CROSSMEMBER (E) TO THE LEFT & RIGHT BOTTOM FRAME SUPPORTS (B) USING THE M12 x 100MM BOLTS (O), MOUNTING FLANGES (U), M12 WASHERS (R), AND M12 LOCK NUTS (T).

INSTALL REAR UPRIGHTS (A) ONTO THE LEFT & RIGHT BOTTOM FRAME SUPPORTS (B) USING THE M12 x 75MM BOLTS (P), MOUNTING FLANGES (U), M12 WASHERS (Q), AND M12 LOCK NUTS (S).

NEXT SLIDE ON THE RUBBER BOOTS (L) TO THE LEFT & RIGHT BOTTOM FRAME SUPPORTS (B) .

## ***SPOTTER & BAR CATCH ASSEMBLY***

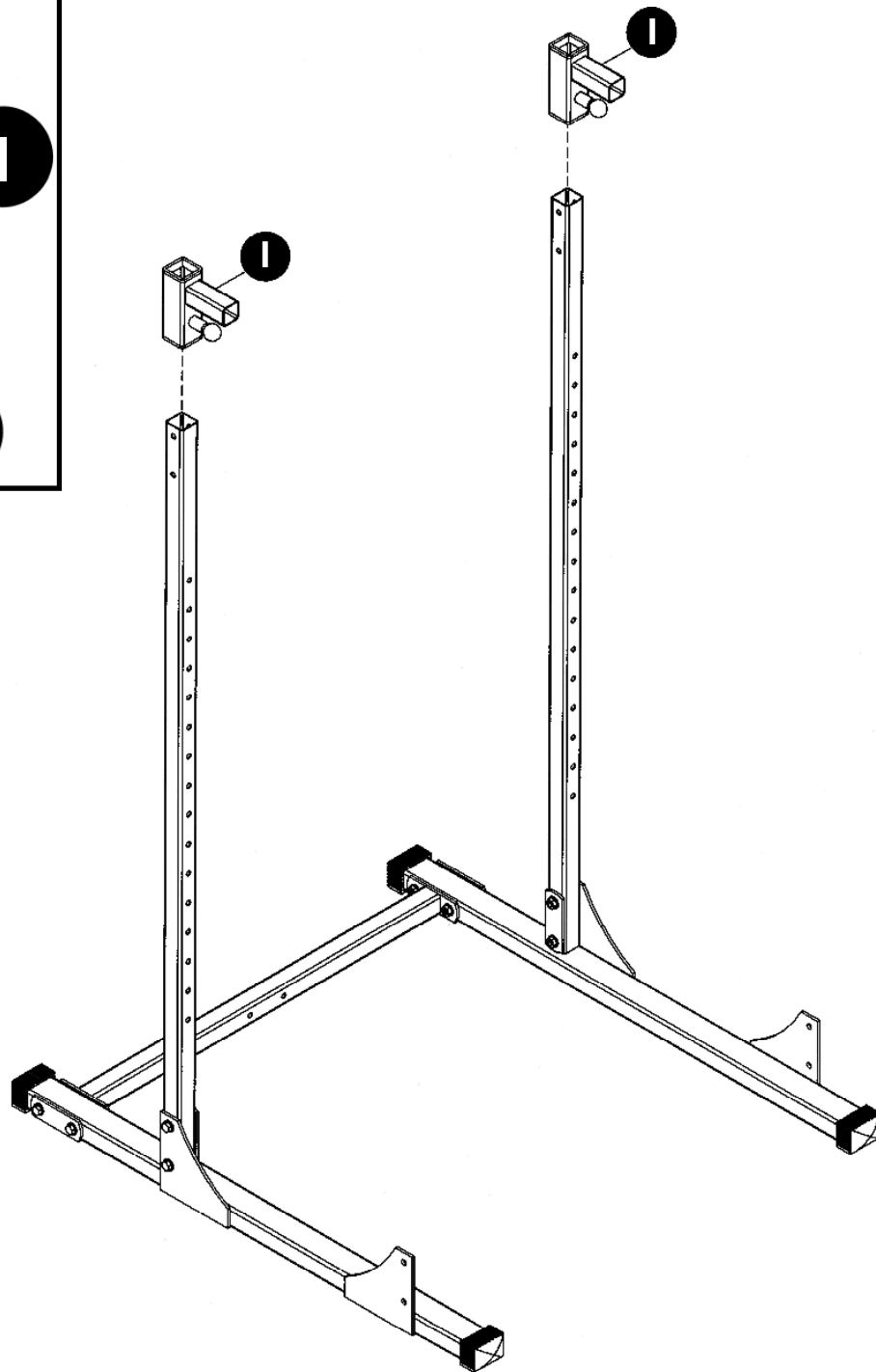
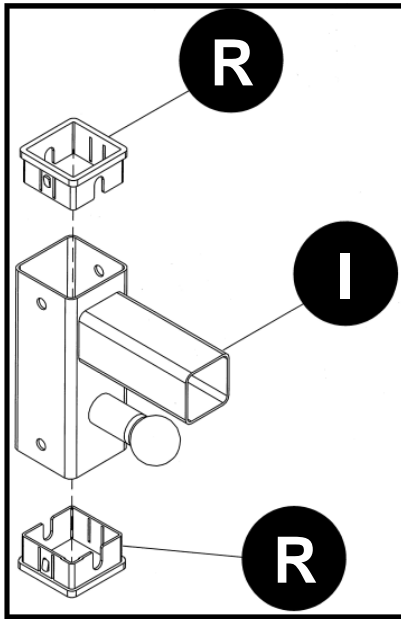

INSTALL REDUCERS (R) INTO EACH END OF REAR SPOTTER BAR, MAKING SURE TO ALIGN TABS ON REDUCERS WITH HOLES IN SPOTTER BARS. REPEAT FOR FRONT SPOTTER BARS AND WEIGHT CATCHES. INSTALL KNOBS INTO FRONT AND REAR BAR CATCHES.

INSTALL THE REAR SPOTTER BARS (I) ONTO THE REAR UPRIGHTS. LOWER TO THE HIGHEST HOLE POSITION AND LOCK INTO PLACE WITH THE LOCK PIN.

## ***SPOTTER BAR INSTALLATION***

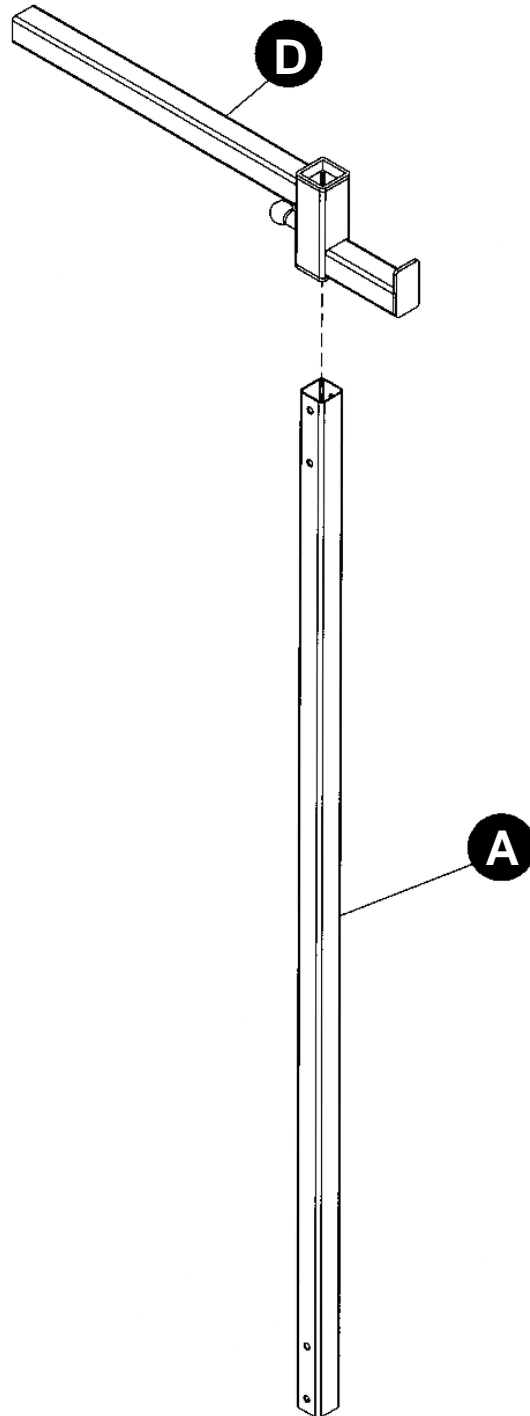

INSTALL THE FRONT SPOTTER BAR (D) ON TO THE FRONT UPRIGHT (A). LOWER TO THE HIGHEST HOLE POSITION AND LOCK INTO PLACE WITH THE LOCK PIN. REPEAT FOR THE OPPOSITE SIDE.

## SPOTTER BAR INSTALLATION

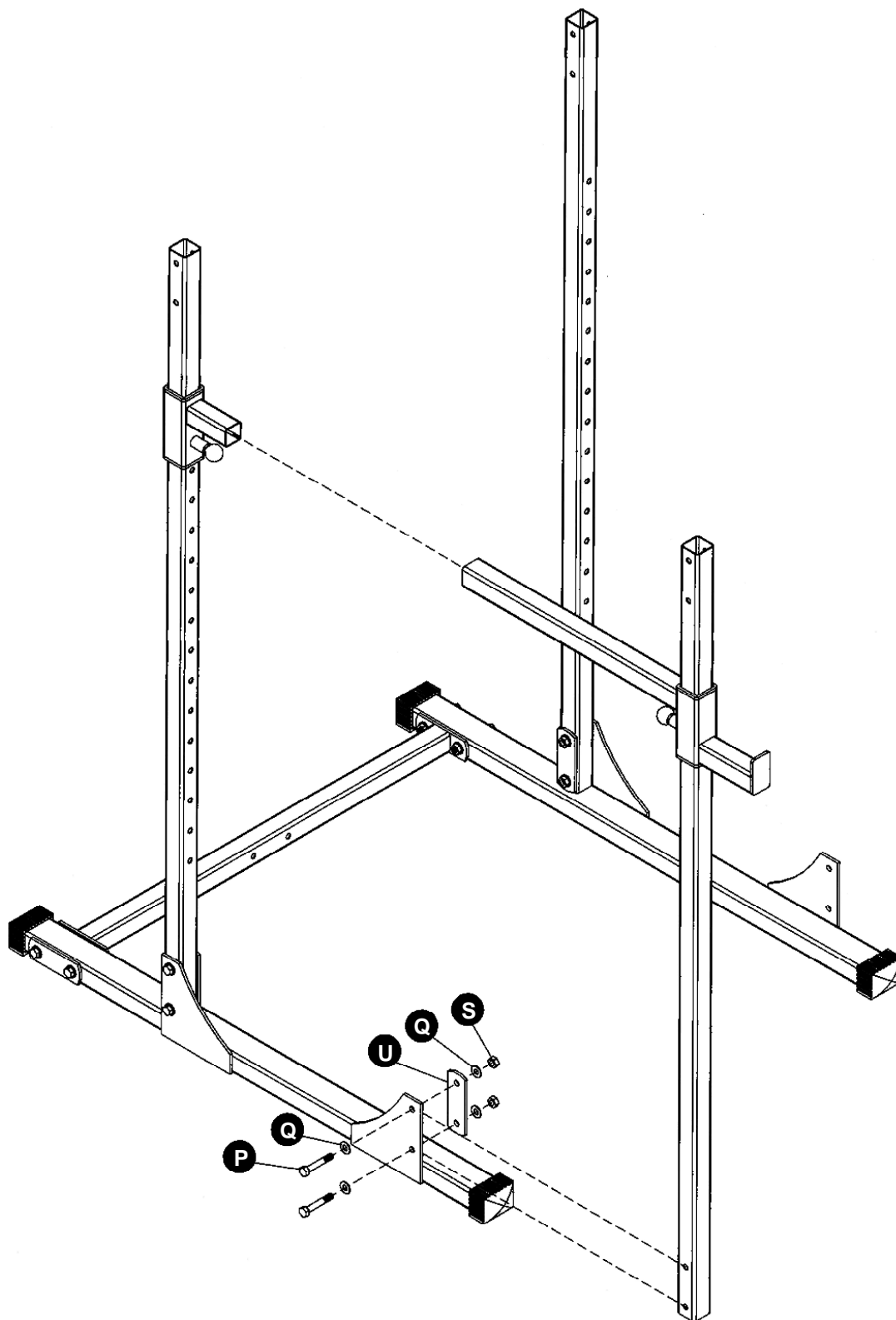

SLIDE THE FRONT SPOTTER BAR INTO THE REAR SPOTTER. INSTALL THE FRONT UPRIGHT TO THE BOTTOM FRAME USING THE M12 x 75MM BOLTS (P), M12 WASHERS (Q), MOUNTING FLANGE (U), AND M12 NUT (S). REPEAT FOR OPPOSITE SIDE.

## BAR CATCH INSTALLATION

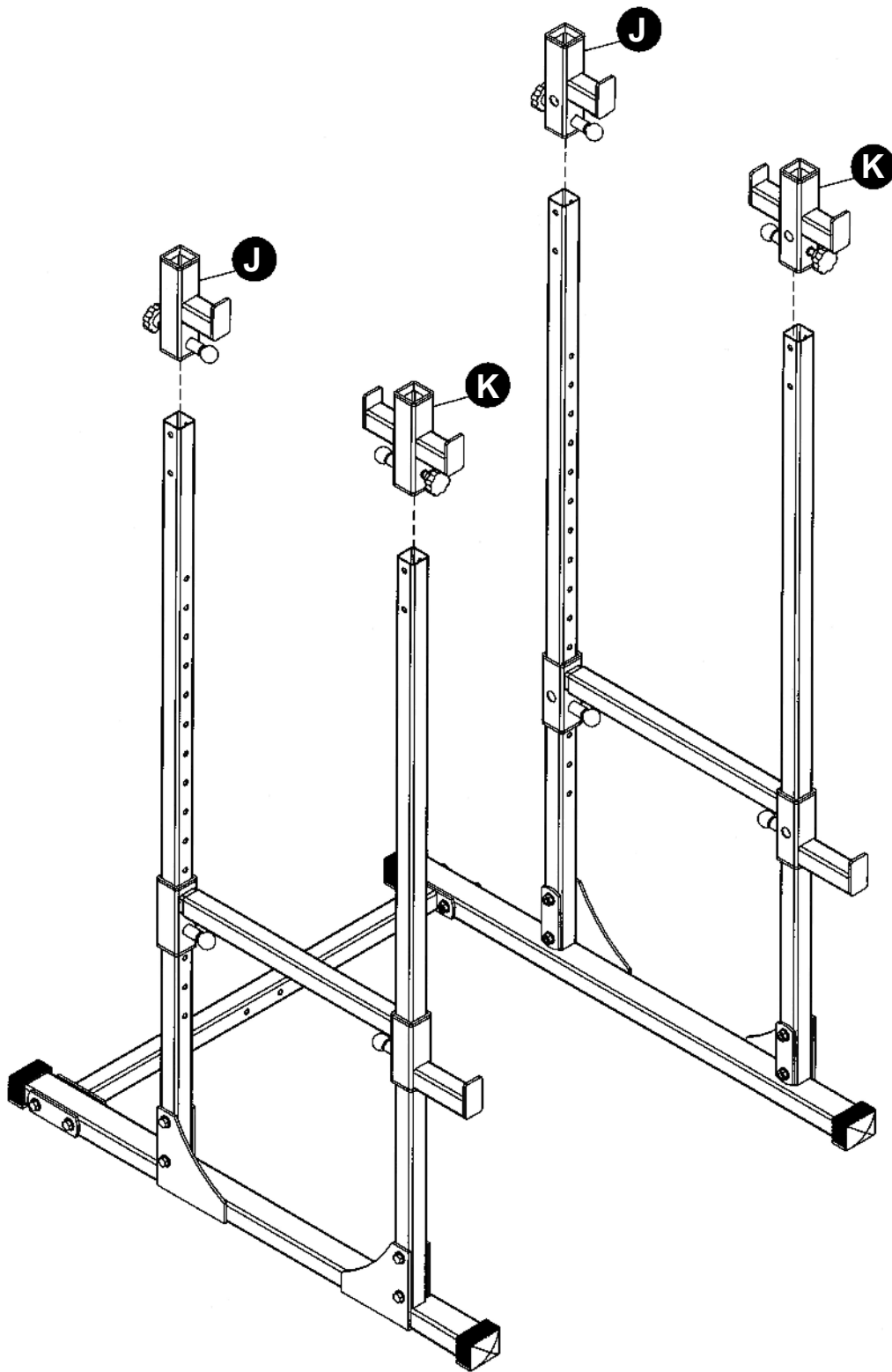

INSTALL THE REAR BAR CATCHES (J), AND FRONT BAR CATCHES (K) AND LOCK INTO PLACE WITH PULL-PINS. THE REAR BAR CATCHES CAN BE INSTALLED FORWARD OR BACKWARD DEPENDING ON YOUR PREFERENCE.



## FRAME ASSEMBLY

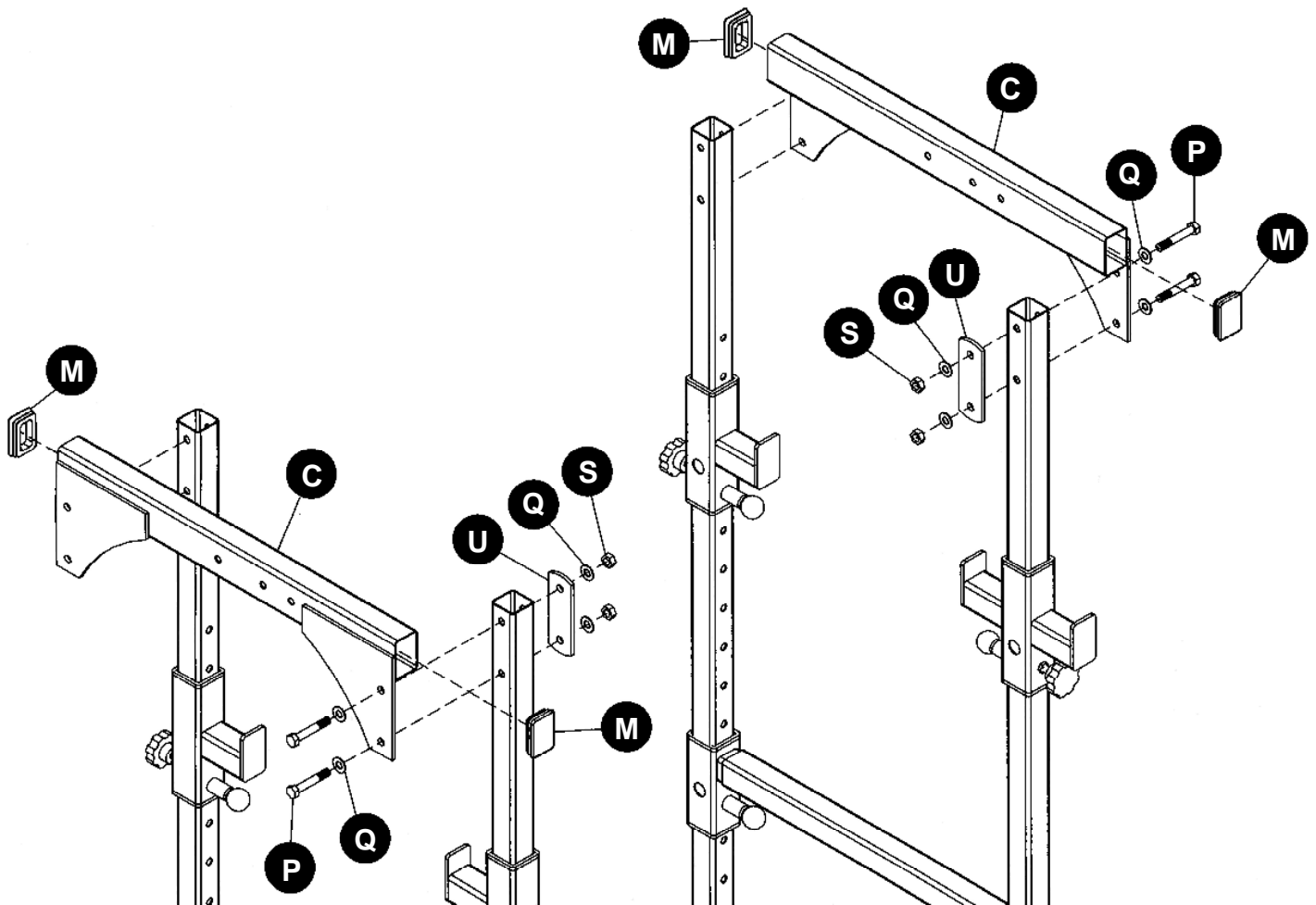

INSERT THE RECTANGULAR CAPS (M) INTO THE ENDS OF THE TOP FRAME SUPPORTS (C).

INSTALL THE LEFT AND RIGHT TOP FRAME SUPPORTS (C), TO THE FRONT UPRIGHTS USING THE M12 x 75MM BOLTS (P), M12 WASHERS (Q), MOUNTING FLANGES (U), AND M12 NUTS (S). DO NOT BOLT TO THE REAR UPRIGHTS AT THIS TIME.

## FRAME ASSEMBLY

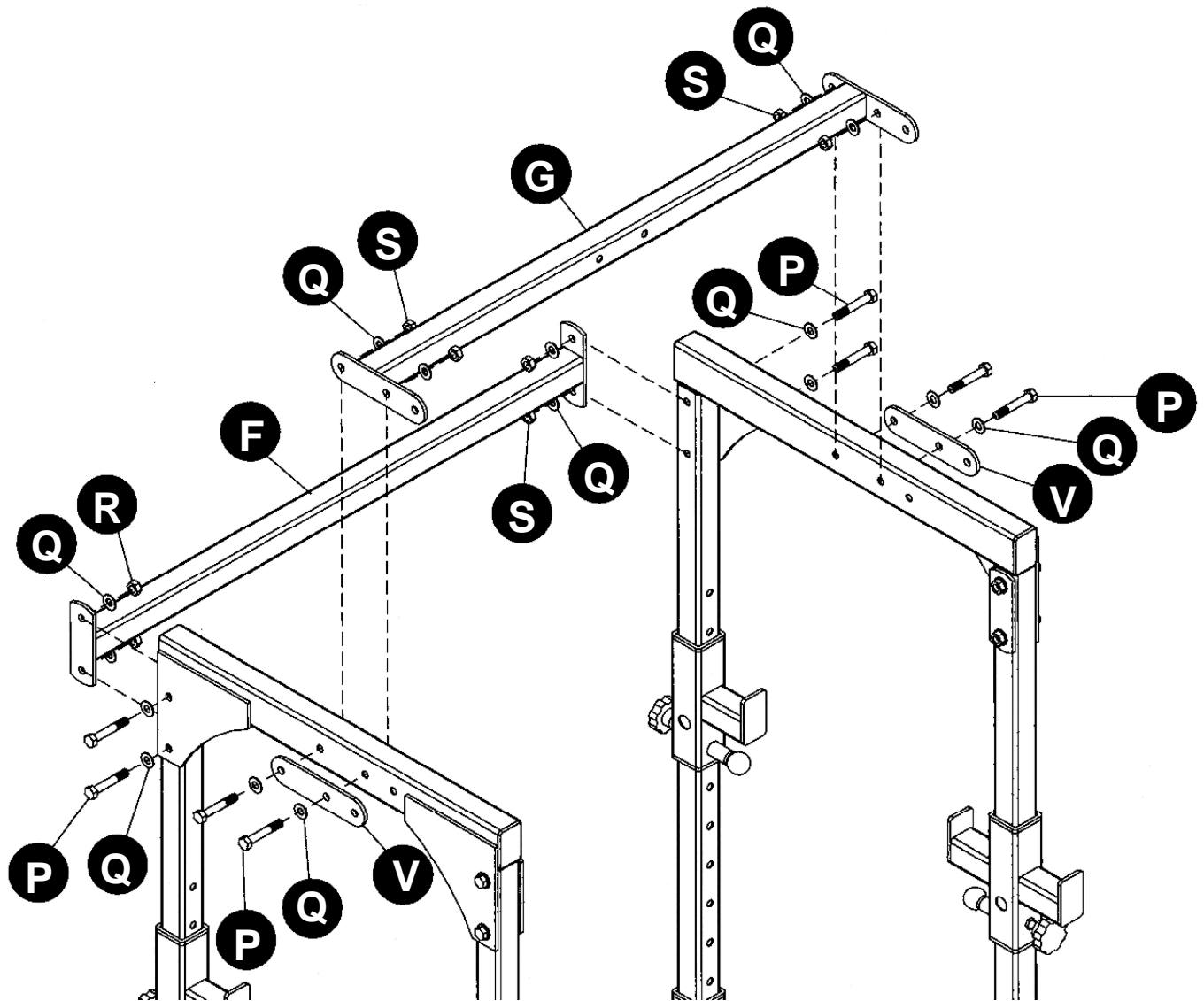

INSTALL THE CHIN-UP BAR ASSEMBLY (G), BETWEEN THE TOP FRAME SUPPORTS USING THE M12 x 75MM BOLTS (P), M12 WASHERS (Q), MOUNTING FLANGES (V), AND M12 NUTS (S).

INSTALL THE UPPER CROSSMEMBER (F), BETWEEN THE REAR UPRIGHTS USING THE M12 x 75MM BOLTS (P), M12 WASHERS (Q), AND M12 NUTS (S).

## CHIN-UP BAR ASSEMBLY

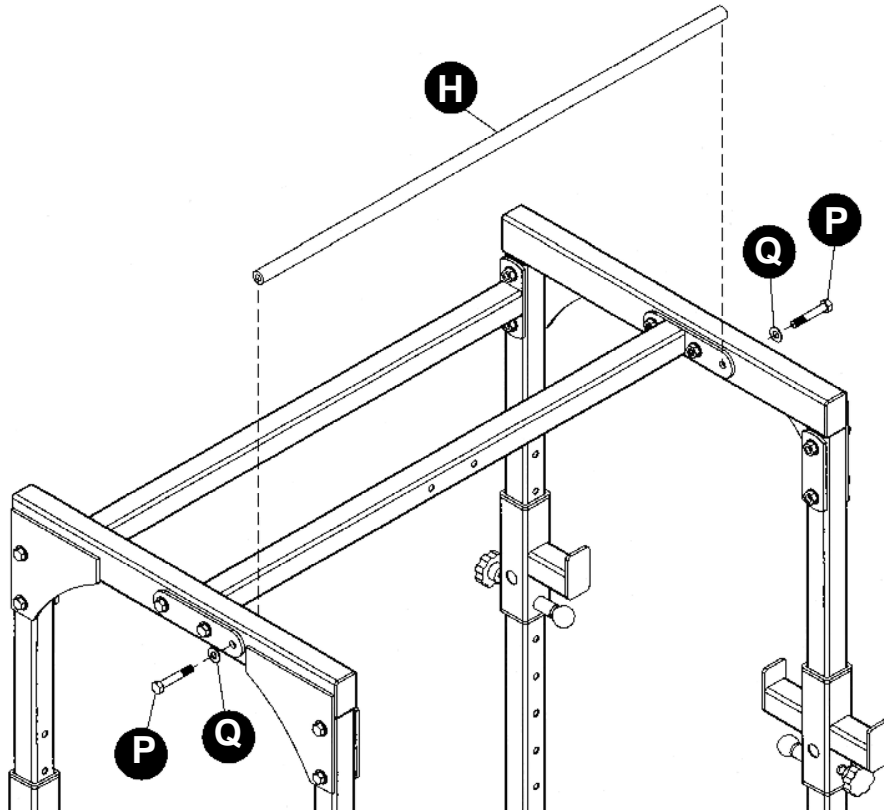

INSTALL THE CHIN-UP BAR (H) INTO THE CHIN-UP BAR ASSEMBLY USING THE M12 x 75MM BOLTS (P), AND M12 WASHERS (Q).

### **ADJUSTING THE WEIGHT HOLDERS:**

RAISE AND LOWER THE WEIGHT HOLDERS BY TURNING THE KNOB TO LOOSEN, THEN USE THE PULL PIN TO MAKE THE HEIGHT ADJUSTMENT. MAKE SURE THE PULL PIN IS SECURE IN THE ADJUSTMENT HOLE THEN TURN THE KNOB TO TIGHTEN BEFORE USE.

\* NOTE MAKE SURE THE WEIGHT HOLDERS ARE THE SAME HEIGHT ON BOTH SIDES BEFORE USE.

### **ADJUSTING THE SPOTTER BARS:**

RAISE AND LOWER THE SPOTTER BARS BY USING THE PULL PINS TO MAKE THE HEIGHT ADJUSTMENT. MAKE SURE THE PULL PIN IS SECURE IN THE ADJUSTMENT HOLE. .

\* NOTE MAKE SURE THE SPOTTER BARS ARE THE SAME HEIGHT ON EACH SIDE BEFORE USE.

# ***SAFETY NOTICE***

WARNING: THE USER OF THIS WEIGHT EQUIPMENT ASSUMES THE POSSIBILITY OF INJURY BY EXERCISING ON THIS EQUIPMENT. THE POSSIBILITY OF RISK CAN BE REDUCED BY ALWAYS FOLLOWING THESE SIMPLE RULES:

- 1) BEFORE BEGINNING ANY EXERCISE PROGRAM, CONSULT YOUR DOCTOR FOR A COMPLETE PHYSICAL EXAMINATION AND SUGGESTED EXERCISE PROGRAM SPECIFIC FOR YOU.
- 2) STRETCH BEFORE AND AFTER THE EXERCISE PROGRAM. PROPER STRETCHING WILL PREPARE YOUR JOINTS AND MUSCLES FOR EXERCISE AND HELP AVOID INJURIES.
- 3) IF AT ANY TIME YOU SHOULD FEEL FAINT OR DIZZY, NAUSEOUS OR EXPERIENCE ANY OTHER ABNORMAL SYMPTOMS OR DISCOMFORT DISCONTINUE USE AND CONSULT YOUR DOCTOR.
- 4) DO NOT USE THIS EQUIPMENT WITHOUT QUALIFIED SUPERVISION AND PROPER TRAINING. NEVER WORK OUT ALONE- ALWAYS HAVE A PARTNER.
- 5) SECURELY TIGHTEN ALL BOLTS AND REGULARLY CHECK TO ENSURE ALL BOLTS HAVE NOT LOOSENED.
- 6) WEAR GOOD RUBBER SOLE SHOES ONLY. DO NOT USE BARE FOOTED OR WITH SOCKS ONLY.
- 7) DO NOT WEAR LOOSE CLOTHES SUCH AS ROBES, GOWNS, PANTS, LONG SHIRTS OR JEWELRY WHICH COULD BECOME ENTANGLED IN MOVING PARTS.
- 8) DO NOT STAND OR KNEEL ON SEAT. ALWAYS SIT OR LAY SQUARELY CENTERED.
- 9) KEEP HEAD, LIMBS AND BODY PARTS CLEAR OF MOVING PARTS AND WEIGHT PLATES.
- 10) CHILDREN SHOULD NOT USE EXERCISE EQUIPMENT WITHOUT SUPERVISION BECAUSE OF POSSIBILITY OF INJURY FROM IMPROPER USAGE. THIS EQUIPMENT IS INTENDED FOR HOME USE ONLY.
- 11) REPLACEMENT OF WORN OR DEFECTIVE PARTS MUST BE WITH FACTORY AUTHORIZED PARTS. IF OTHER THAN FACTORY AUTHORIZED PARTS OR ASSESSORS ARE USED ALL WARRANTIES AND LIABILITIES BECOME VOID.

# DF4500 ACCESSORIES

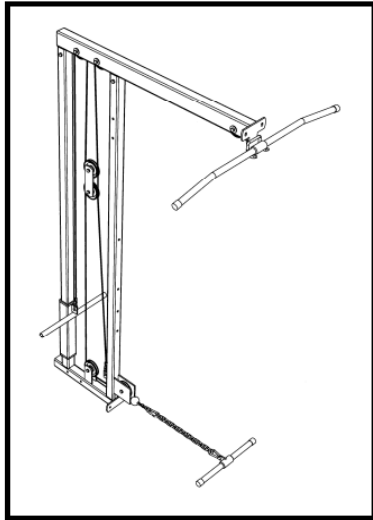

**DF830– Lat Attachment** Add lat Pulldown and Low Row exercises to your Power Rack. Get more information at [www.fitnessdestination.com](http://www.fitnessdestination.com)

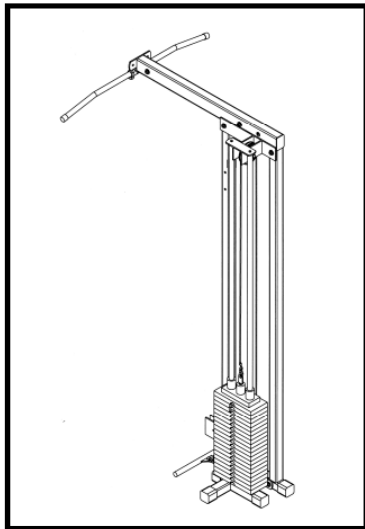

**DF838– Stack Loaded Lat Attachment** Add lat Pulldown and Low Row exercises to your Power Rack with the easy selection of a 200 lb. weight stack. Get more information at [www.fitnessdestination.com](http://www.fitnessdestination.com)

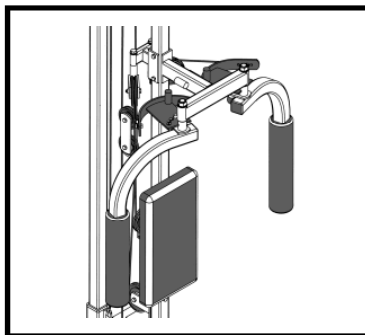

**DF1200** Add lat pulls to your bench with this lat attachment. You can find more information at [www.fitnessdestination.com](http://www.fitnessdestination.com)

# ***EXERCISES***



**SQUAT**



**TOE RAISE**



**SHRUG**



**FLAT BENCH PRESS**

# ***EXERCISES***



**INCLINE PRESS**



**DECLINE PRESS**



**MILITARY PRESS**



**CHIN-UP**