

Body-Solid

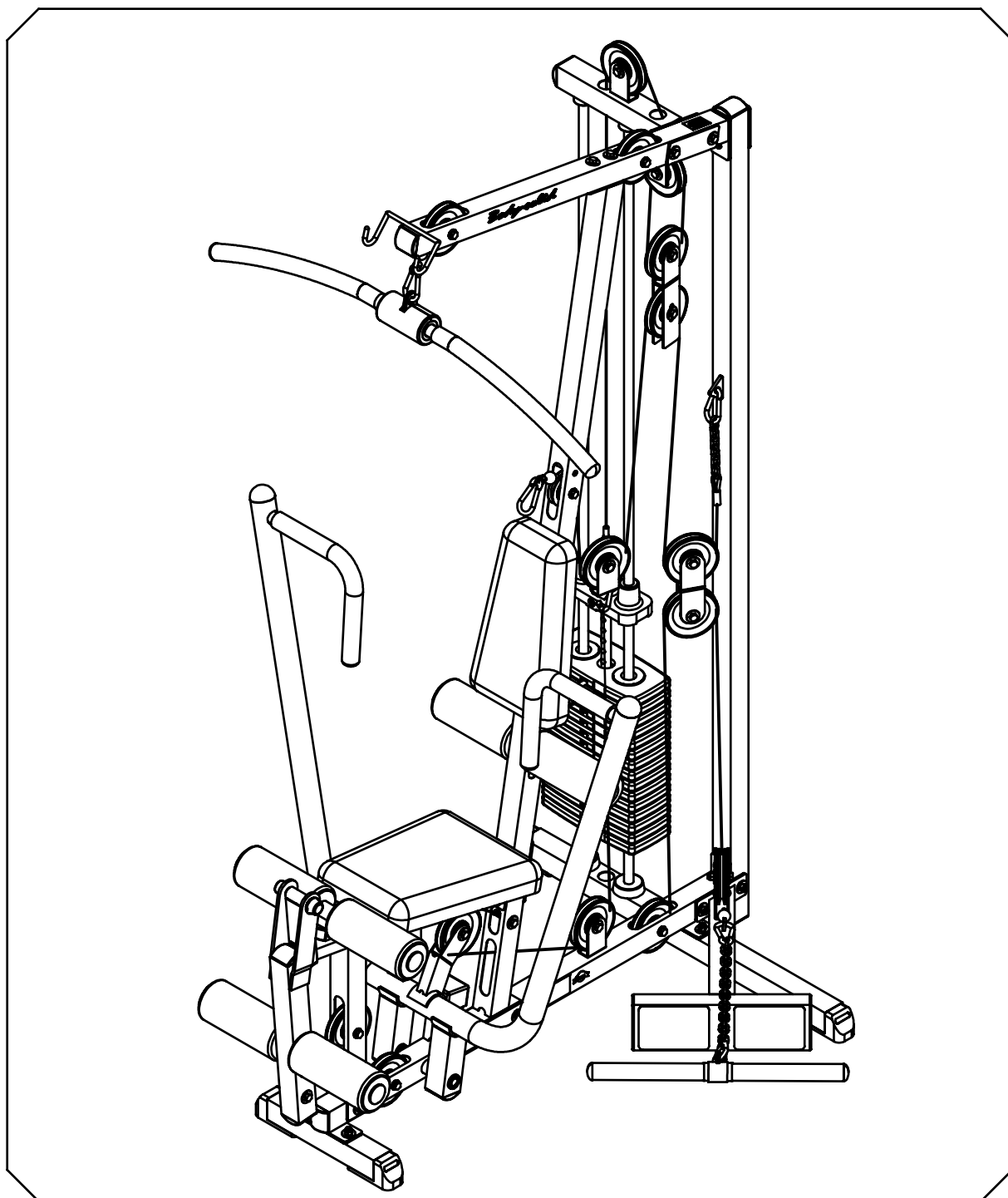

BODY-SOLID, Inc.
1900 S. Des Plaines Ave.
Forest Park, IL 60130 USA
Phone: (708) 427-3555
Fax: (708) 427-3556
www.bodysolid.com

EXM-1500G OWNER'S MANUAL

TABLE OF CONTENTS

General Instructions.....	2
Training Tips and Safety Information.....	3
Hardware Illustrations.....	4-5
Parts Illustrations.....	6
Assembly (Step 1)	7-8
Assembly (Step 2)	9-10
Assembly (Step 3)	11-12
Assembly (Step 4)	13-14
Assembly (Step 5)	15-16
Assembly (Step 6)	17-18
Assembly (Step 7)	19-20
Assembly (Step 8)	21-22
Assembly (Step 9)	23-24
Cable Adjustments.....	25
Inspections and Maintenance Schedule.....	26

EXM-1500G ASSEMBLY INSTRUCTIONS

GENERAL INSTRUCTIONS

Thank you for purchasing the Body-Solid EXM1500S Gym. At Body-solid, our goal is to ensure customer satisfaction. If you have any questions about these instructions or have any problems with assembly or parts for this machine, please call our Customer Service Department at 1-800-556-3113.

Prior to assembling any Body-Solid machine, please take the time to read the instructions thoroughly. Please use this manual to make sure that all parts have been included with your shipment. When ordering replacement parts, please refer to the part number and description of each part from this manual. Use only Body-Solid replacement parts when servicing any Body-Solid machine. Failure to do so may void your warranty and could result in personal injury.

Body-Solid equipment is designed to provide the safest, smoothest and most effective workouts possible. After you have finished assembling this product, check all stations to ensure correct operation. If for some reason you experience problems with any functions of this machine, do not continue operation. First, re-check all of the assembly instructions to locate any possible errors made during assembly. If you are not able to correct the problem, contact our Customer Service Department immediately at 1-800-556-3113.

TOOLS REQUIRED

Socket Wrench

5/16"、 3/8" and 1/2" Sockets

Crescent Wrench

Rubber Mallet

Tape Measure

5/16" Allen Wrench (included)

5/32" Allen Wrench (included)

TRAINING TIPS AND SAFETY INFORMATION

Before starting any exercise program, it is recommended that you consult your physician and get a complete physical examination. There is a risk assumed by individuals who use this type of equipment. To minimize risk, follow the rules below.

Always consult your physician before starting any exercise program.

Do not allow children or minors to play on or around the equipment.

Warm up properly before engaging in any weight training regimen.

Before using, read all the warning labels and instructions on the use of this machine.

Do not modify the machine in any way.

Inspect the machine before use for any damaged, worn or missing parts. If there is any doubt about the ability of this equipment to operate safely, do not use the equipment until it is serviced.

Exercise with care, performing exercises at a smooth, moderate pace. Never perform jerky or uncoordinated movements that may result in injury.

Never hold your breath while exercising.

Learn how to perform the exercise correctly before using heavy weight. Correct form is important to avoid injury and to ensure that you work the proper muscle groups.

It is recommended that you train with a training partner.

Keep body and clothing clear of cables and moving parts when the machine is in use.

Know your limitations. If you are new to resistance training or are starting an exercise routine after a prolonged lay-off, start slowly and build up to a more intense routine.

Failure to follow these rules may result in serious injury. If unsure about the proper use of the machine, consult your local Body-Solid distributor or call the Body-Solid Customer Service department at 1-800-556-3113.

EXM-1500G ASSEMBLY INSTRUCTIONS





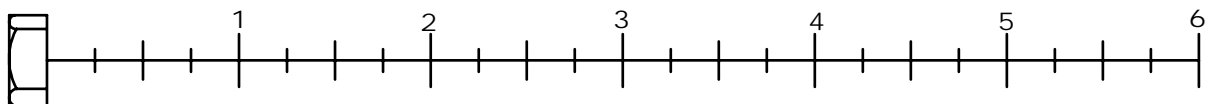
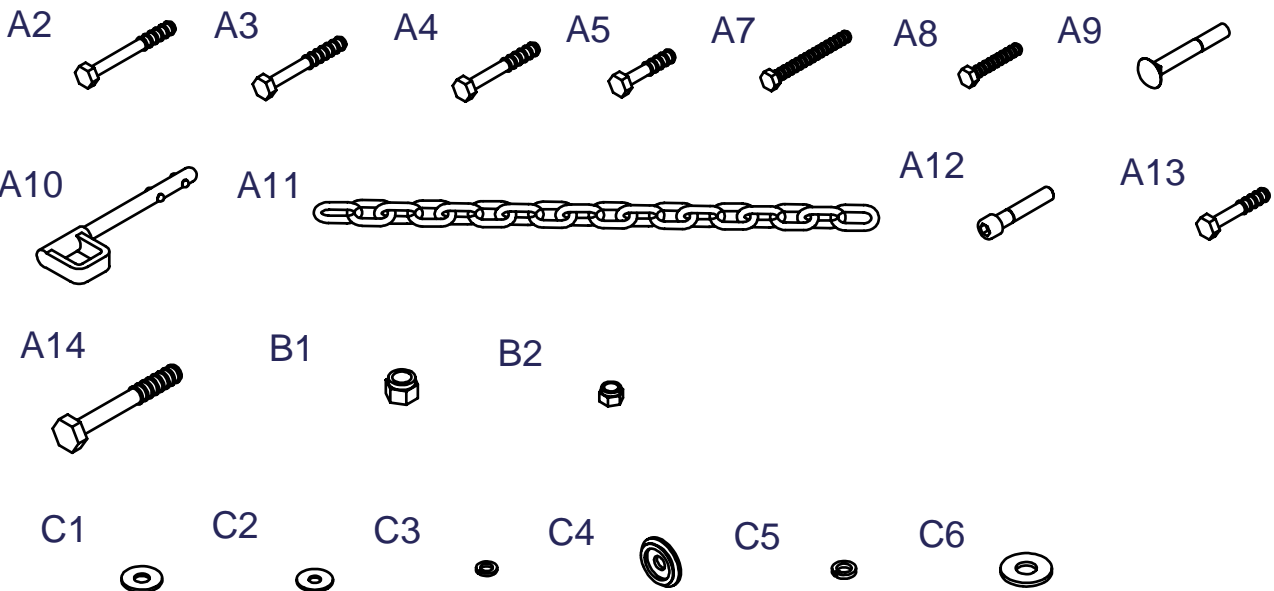



HARDWARE ILLUSTRATION

A2.	3/8"x3" Hex Head Bolt-----	[7PCS]
A3.	3/8"x2 3/4" Hex Head Bolt-----	[12PCS]
A4.	3/8"x2 1/2" Hex Head Bolt-----	[4PCS]
A5.	3/8"x1 3/4"Hex Head Bolt-----	[9PCS]
A7.	5/16"x2 3/4"Hex Head Bolt-----	[2PCS]
A8.	5/16"x1 3/4"Hex Head Bolt-----	[2PCS]
A9.	3/8"x2 3/4"CARRIAGE BOLT-----	[4PCS]
A10.	SELECTOR PIN-----	[1PCS]
A11.	STEEL CHAIN-----	[1PCS]
A12.	3/8"x2" ROUND BOLT-----	[1PCS]
A13.	3/8"x2" Hex Head Bolt-----	[1PCS]
A14.	1/2"x3 3/4" Hex Head Bolt-----	[1PCS]
B1.	1/2" NYLON LOCK NUT-----	[2PCS]
B2.	3/8" NYLON LOCK NUT-----	[33PCS]
C1.	3/8"(I.D)WASHER-----	[44PCS]
C2.	5/16"(I.D)WASHER-----	[4PCS]
C3.	5/16" SPRING WASHER-----	[4PCS]
C5.	3/8" SPRING WASHER-----	[1PCS]
C4.	1/2" ROUND END CAP WASHER-----	[2PCS]
C6.	1/2" WASHER-----	[2PCS]

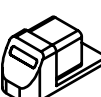
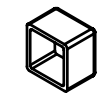

EXM-1500G ASSEMBLY INSTRUCTIONS

HARDWARE ILLUSTRATION

D1. 2"x2"x1.8t ROUND END CAP(9211-087)-----[8PCS]	D1	
D2. 2"x2"x2.5t ROUND END CAP(9211-088)-----[1PCS]	D2	
D3. 2"x4" END CAP(9211-014)-----[2PCS]	D3	
D4. 1"x2" END CAP(9211-086)-----[3PCS]	D4	
D5. 1 3/4"x1 3/4" END CAP(9211-004)-----[1PCS]	D5	
D6. Ø1" CHROME END CAP(8341-033)-----[6PCS]	D6	
D7. 2"x2" FOOT CAP(9211-024)-----[4PCS]	D7	
D8. 2"x2" ROUBBER CAP(9310-020)-----[1PCS]	D8	
D9. Ø2 1/2" RUBBER DOUNT(9310-010)-----[2PCS]	D9	
D10. Ø8mm SPRING SNAP LINK(8810-001)-----[5PCS]	D10	
D11. Ø16 STEEL BUSHING(9211-041)-----[12PCS]		
D13. 95X140mm NO SLIP TAPE(9310-035)-----[2PCS]		
D14. Ø110(4 1/4")PULLEY(9213-002C)-----[15PCS]		
D15. Ø3"PULLEY(9213-006)-----[1PCS]		
D16. Ø3 1/2x8" FOAM ROLLER(9161-007)-----[6PCS]		
D17. TOP PLATE(8400-005)-----[1PCS]		
D18. WEIGHT SELECTOR BAR(8210-052A)-----[1PCS]		
D19. 1/2" BOLT CAP-----[2PCS]		
D20. 1440mm STEEL CABLE-----[1PCS]		
D21. 3235mm STEEL CABLE-----[1PCS]		
D22. 3050mm STEEL CABLE-----[1PCS]		
D23. 2210mm STEEL CABLE-----[1PCS]		
D25. Ø3" NYLON WASHER(9214-008)-----[8PCS]		
D26. 38X4tx38 RUBBER PAD(9310-001)-----[1PCS]		
D28. Ø3/4 SHAFT COOLAR(9211-046)-----[2PCS]		
D29. 10LB SELECTOR PLATE-----[15PCS]		
D30. Ø1" ROUND END CAP(9260-021)-----[6PCS]		
D31. Ø50 ROUND END CAP(9211-080)-----[2PCS]		

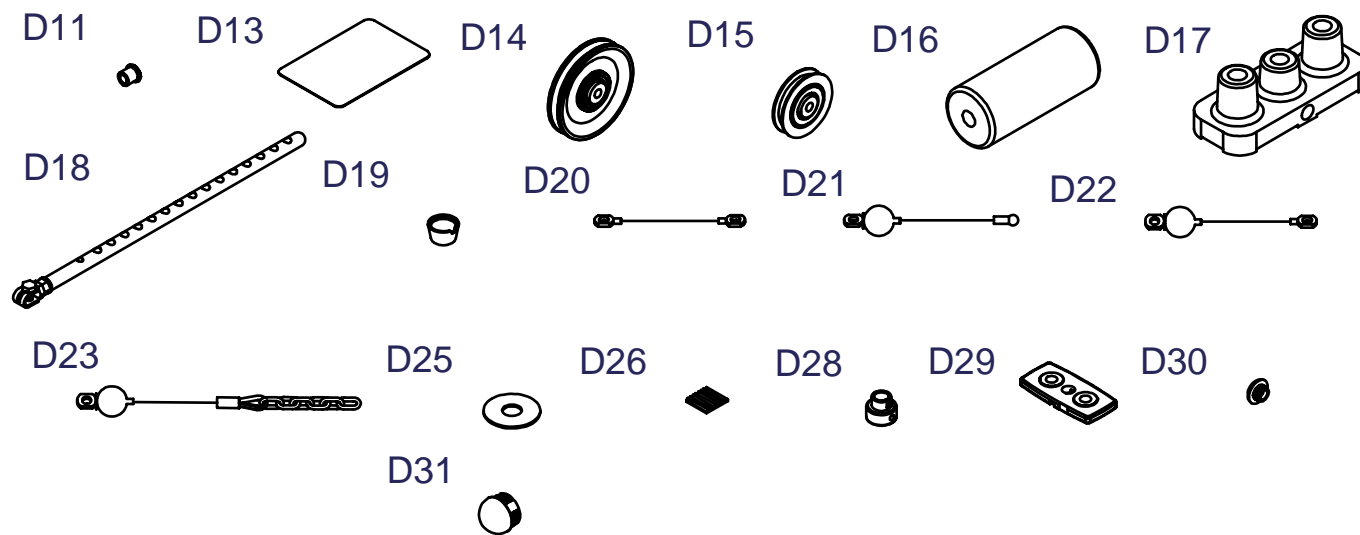

EXM-1500G ASSEMBLY INSTRUCTIONS

PARTS ILLUSTRATION SHEET

A.MAIN BASH FRAME[1PCS]

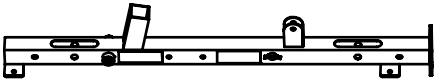

B.REAR BASE FRAME[1PCS]

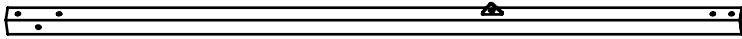

C.ANGLED SUPPORT PILLAR[1PCS]



D.TOP FRAME[1PCS]



E.BENCH PRESS FRAME[1PCS]

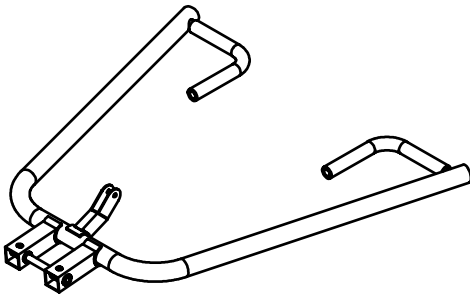

L.WELDED DOUBLE BRACKET[1PCS]



M.SINGLE PULLEY HOOK[1PCS]



J.FOOT BRACE

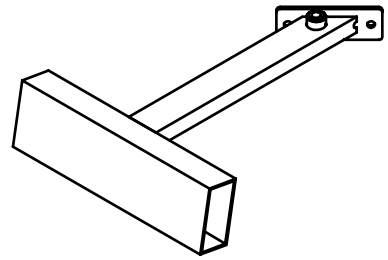

K.LOW PULLEYBRACKET(1PCS]

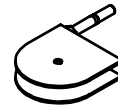

N.WELDED "ADJUSTABLE" DOUBLE BRACKET[1PCS]

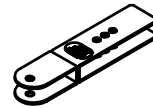

O.REAR BASE FRAME[1PCS]

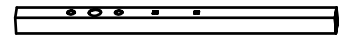

P.FRONT BASE FRAME[1PCS]

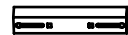

F.SEAT/EXTENSION FRAME[1PCS]

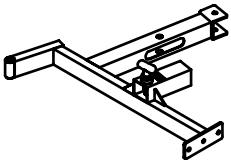

Q.CHROME GUIDE ROD[2PCS]



R.FOAM ROLLER BAR[3PCS]



G.LEG FRAME[1PCS]

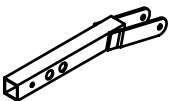

S.2"x5 1/2" PLATE[2PCS]
8312-090

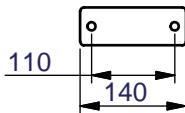

H.SEAT FRAME[1PCS]

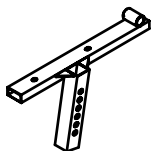

T.2"x4" PLATE[1PCS]
8312-049

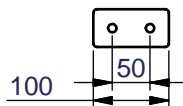

W.SEAT PAD
9123-010

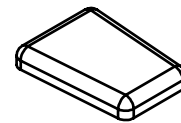

I.TOP WEIGHT STACK FRAME[1PCS]

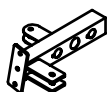

U.LAT BAR[1PCS]
20LB1100D

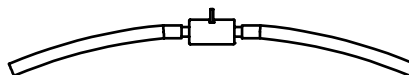

X.BACK PAD
9113-006

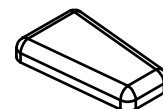

V.LOW ROW BAR[1PCS]
20LB500C



ASSEMBLY- STEP 1

****Note :** Do Not fully tighten frame bolts and nuts until after completing Step 3

****Note :** Do Not fully tighten pulley bolts and nuts until after cable routing

The following Parts and Hardware will be needed to complete Step 1

Parts Description

Hardware Description

<u>Qty</u>	<u>Part</u>	<u>Part Description</u>	<u>Qty</u>	<u>Part</u>	<u>Part Description</u>
1	A	Main Base Frame	2	A2	3/8"x3" hex head bolt
1	B	Vertical Support Pillar	5	A3	3/8"x2 3/4" hex head bolt
1	C	Angled Support Pillar	1	A5	3/8"x1 3/4" hex head bolt
1	O	Rear Base Frame	4	A9	3/8"x2 3/4" carriage bolt
1	P	Front Base Frame	12	B2	3/8" nylon lock nut
			14	C1	3/8" I.D. washer
			2	D1	2"x2"x1.8t round end cap
			1	D2	2"x2"x2.5t round end cap
			4	D7	2"x2" foot cap
			1	D8	2"x2" rubber cap
			6	D11	phi 16 nylon bushing
			3	D14	4 1/2" pulley
			1	D15	3" pulley

Step by Step

1. Attach 4 (D7) - Foot Caps to (P) Front Base Frame and (O) Rear Base Frame
2. Attach (A) - Main Base Frame to (O) - Rear Base Frame
3. Attach (A) - Main Base Frame to (P) - Front Base Frame
4. Attach (C) - Angled Support Pillar to (A) - Main Base Frame
5. Attach (B) - Vertical Support Pillar to (A) - Main Base Frame
6. Attach 3 (D14) and 1 (D15) pulleys to frame as shown
(Note : DO NOT fully tighten pulley bolts and nuts until after cable routing)

ASSEMBLY STEP 1

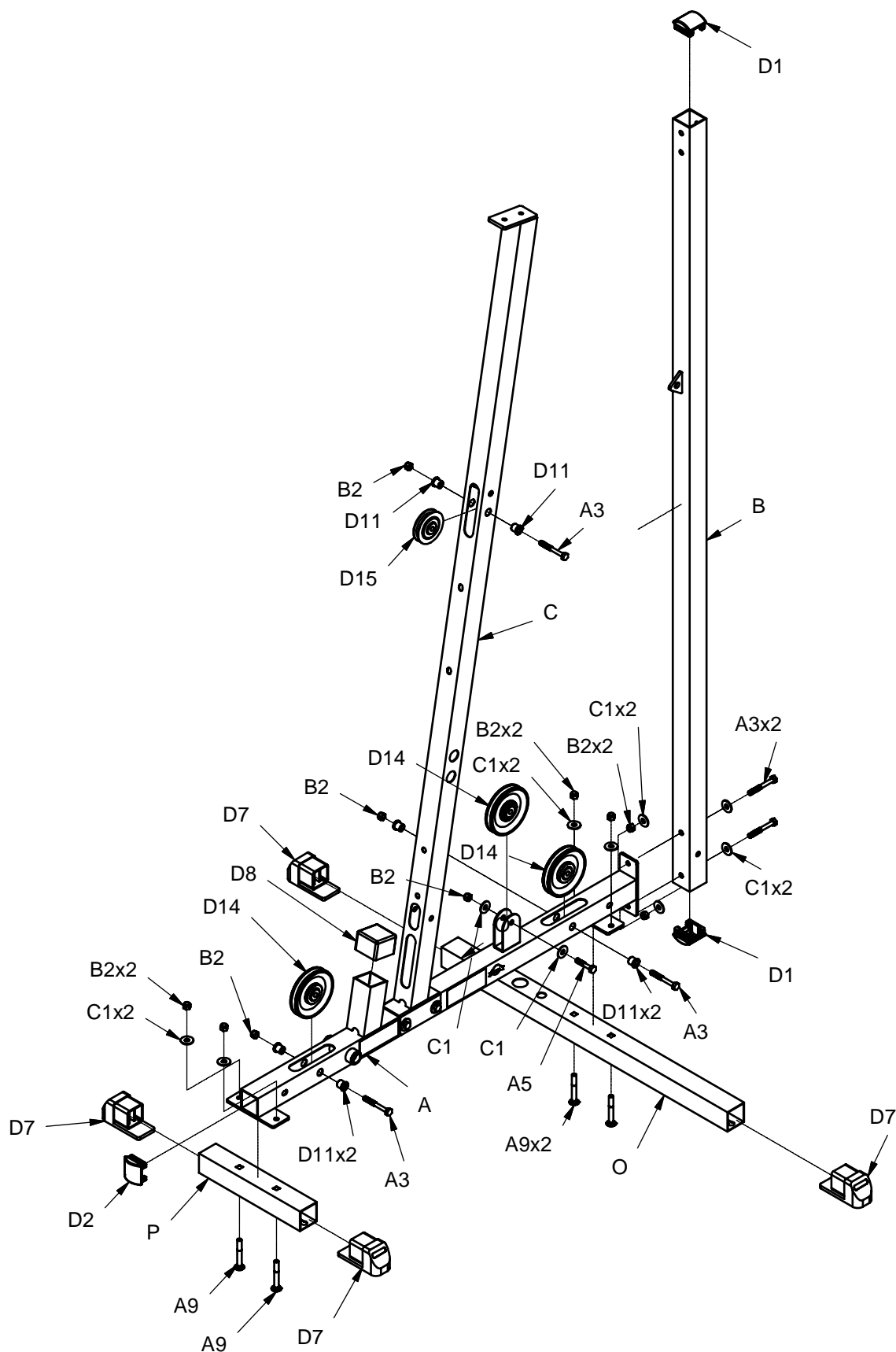

ASSEMBLY- STEP 2

****Note :** Do Not fully tighten frame bolts and nuts until after completing Step 3

****Note :** Do Not fully tighten pulley bolts and nuts until after cable routing

The following Parts and Hardware will be needed to complete Step 2

Parts Description

Hardware Description

<u>Qty</u>	<u>Part</u>	<u>Part Description</u>	<u>Qty</u>	<u>Part</u>	<u>Part Description</u>
1	D	Top Frame	4	A3	3/8"x2 3/4" hex head bolt
1	E	Bench Press Frame	2	A4	3/8"x2 1/2" hex head bolt
1	R	Foam Roller Bar	1	A5	3/8"x1 3/4" hex head bolt
1	T	2"x4" Plate	3	B2	3/8" nylon lock nut
			6	C1	3/8" I.D. washer
			3	D1	2"x2"x1.8t round end cap
			2	D6	phi 1" round end cap
			4	D11	phi 16 nylon bushing
			3	D14	4 1/4" pulley
			2	D16	phi 3 1/2"x8" foam roller
			2	D25	phi 3" nylon washer
			2	D30	Round end cap
			2	D31	Round end cap

Step by Step

1. Attach (D) - Top Frame to (C) - Angled Support Pillar
2. Attach (D) - Top Frame to (B) - Vertical Support Pillar and (T) - 2"x4" Plate
3. Attach (R) - Foam Roller Bar to (B - Vertical Support Pillar using 2 (D16), 2 (D25), and 2 (D6)
4. Loosen allen head screws at the bottom of (E) - Bench Press Frame. Slide out pivot shaft inside of (E) - Bench Press Frame.
5. Attach (E) - Bench Press Frame to (A) - Main Base Frame, (note : once (E) and (A) are attached and pivot shaft is back in place, re-tighten allen head screws at the bottom of (E)
6. Attach 3 (D14) pulleys to frame to (E) - Bench Press Frame and (D) - Top Frame as shown

(Note : Do Not fully tighten pulley bolts and nuts until after cable routing)

(Note: When attaching the (D14) Pulley to (E) Bench Press Frame the threaded side of the pulley bolts must face the right side if you are standing in front of the unit, facing the unit.)

ASSEMBLY STEP 2

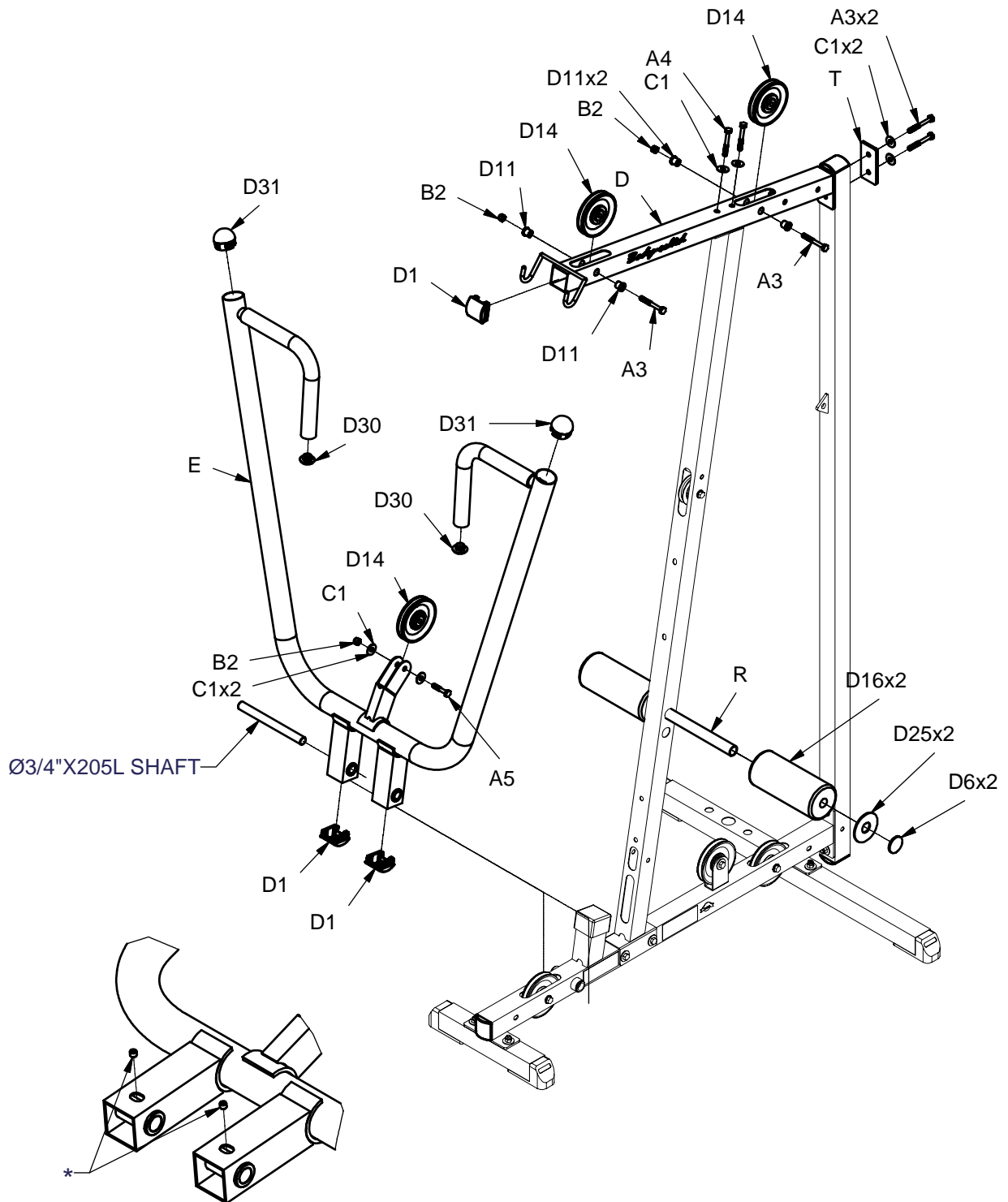

*: NEED TO LOOSEN BOTH ALLEN HEAD BOLT
IN ORDER TO REMOVE SHAFT

ASSEMBLY- STEP 3

****Note :** Do Not fully tighten frame bolts and nuts until after completing Step 3

****Note :** Do Not fully tighten pulley bolts and nuts until after cable routing

The following Parts and Hardware will be needed to complete Step 3

Parts Description			Hardware Description		
Qty	Part	Part Description	Qty	Part	Part Description
15	D29	Weight Stack Plates	2	A2	3/8"x3" hex head bolt
1	I	Top Weight Stack Frame	1	A5	3/8"x1 3/4" hex head bolt
2	Q	Guide Rods	1	A10	Selector pin
1	S	2"x5 1/2" Plate	1	A12	3/8"x2" round bolt
			1	A13	3/8"x2" hex head bolt
			4	B2	3/8" nylon lock nut
			8	C1	3/8" I.D. washer
			1	C5	3/8" spring washer
			1	D1	2"x2"x1.8t end cap
			2	D9	phi 2 1/2" rubber donut
			2	D14	4 1/4" pulley
			1	D17	top plate
			1	D18	weight selector bar
			2	D28	phi3/4" shaft collar

Step by Step

- Place 2 (D9) on (O) - Rear Base Frame, slide 2 (Q) - Guide Rods into 2 (D9) and (O)- Rear Base Frame
- Slide 15 (D29) - Weight Stack Plates onto 2 (Q) - Guide Rods (note : make sure housing for selector pin on Weight Stack Plates is facing forward as shown)
- Slide (D17) - Top Plate onto 2 (Q) - Guide Rods (note:make sure that housing for (A12) - Round Bolt is facing forward as shown)
- Slide (D18) - Selector Shaft into center of weight stack. Connect (D17) - Top Plate to (D18) - Selector Shaft using (A12) - Round Bolt
- Slide 2 (D28) - Shaft Collars onto 2 (Q) - Guide Rods (note : If (D28) - Shaft Collars do not slide onto 2 (Q) - Guide Rods, make sure that the allen head screws in (D28) are loose)
- Attach (S) 2"x5 1/2" Plate and (I) - Top Weight Stack Frame to (D) - Top Frame and 2 (Q) - Guide Rods
- Secure 2 (D28) into (I) - Top Weight Stack Frame. Re-tighten allen head screws
- Attach 2 (D14) pulleys to frame to (I) - Top Weight Stack Frame as shown (Note : Do Not fully tighten pulley bolts and nuts until after cable routing)

Securely Tighten All Frame Bolts Used in Steps 1-3, (Note : Leave Pulley Bolts Loose Until Cable Routing)



EXM-1500G ASSEMBLY INSTRUCTIONS

ASSEMBLY STEP 3

THERE IS A RISK ASSUMED BY INDIVIDUALS WHO USE THIS TYPE OF EQUIPMENT. TO MINIMIZE RISK, YOU MUST FOLLOW THESE RULES:

1. Inspect equipment before each workout. Check that all nuts, bolts, screws and pop pins are in place and fully tightened. Also, before use, check cables for signs of wear. Replace all worn parts immediately. Never use machine if any parts are damaged or missing. Failure to follow these rules may result in serious injury.
2. Keep clear of the cables and all moving parts when the machine is in use.
3. Always make sure all Snap Links are closed when doing any cable/pulley exercises.
4. Exercise with care. Perform your exercises at a smooth moderate pace; never perform jerky or uncoordinated movements that may cause injury.
5. It is recommended that you should workout with a training partner.
6. Do not allow children or minors to play on or around this equipment.
7. If unsure of proper use of equipment, call your local Body-Solid distributor or the Body-Solid customer service department at 1-800-556-3113.
8. **WARNING:** Consult your physician before starting your exercise program. For your own safety, do not begin any exercise program without proper instruction.

RAL2-11-98

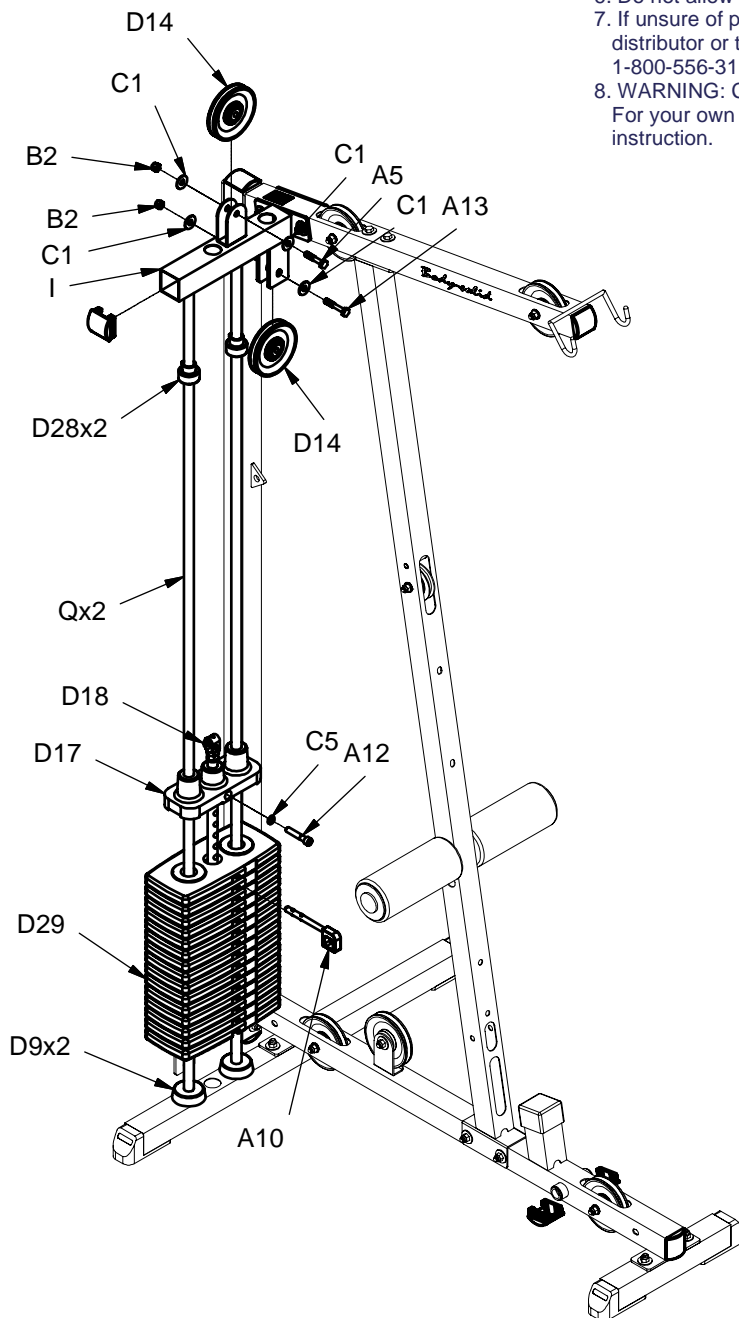

ASSEMBLY- STEP 4

****Note :** Do Not fully tighten frame bolts and nuts until after completing Step 4

****Note :** Do Not fully tighten pulley bolts and nuts until after cable routing

The following Parts and Hardware will be needed to complete Step 4

Parts Description

Hardware Description

<u>Qty</u>	<u>Part</u>	<u>Part Description</u>	<u>Qty</u>	<u>Part</u>	<u>Part Description</u>
1	F	Seat / Extension Frame	3	A2	3/8"x3" hex head bolt
1	J	Foot Brace	3	A3	3/8"x2 3/4" hex head bolt
1	K	Low Pulley Bracket	1	A5	3/8"x1 3/4" hex head bolt
1	S	2"x5 1/2" Plate	1	B1	1/2" nylon lock nut
			7	B2	3/8" nylon lock nut
			12	C1	3/8" I.D. washer
			2	C6	1/2" I.D. washer
			2	D3	2"x4" end cap
			1	D4	1"x2" end cap
			2	D11	phi 16 nylon bushing
			2	D13	no slip tape
			2	D14	4 1/4" pulley
			1	D26	rubber pad

Step by Step

1. Attach (K) - Low Pulley Bracket to (J) - Foot Brace
2. Attach (K) - Foot Brace to (A) - Main Base Frame
3. Attach (F) - Seat / Extension Frame and (S) - 2"x5 1/2" Plate to (C) - Angled Support Pillar and (A) - Main Base Frame
4. Attach 1 (D14) pulleys to frame to (D) - Seat / Extension Frame as shown (Note : Do Not fully tighten pulley bolts and nuts until after cable routing)

EXM-1500G ASSEMBLY INSTRUCTIONS

ASSEMBLY STEP 4

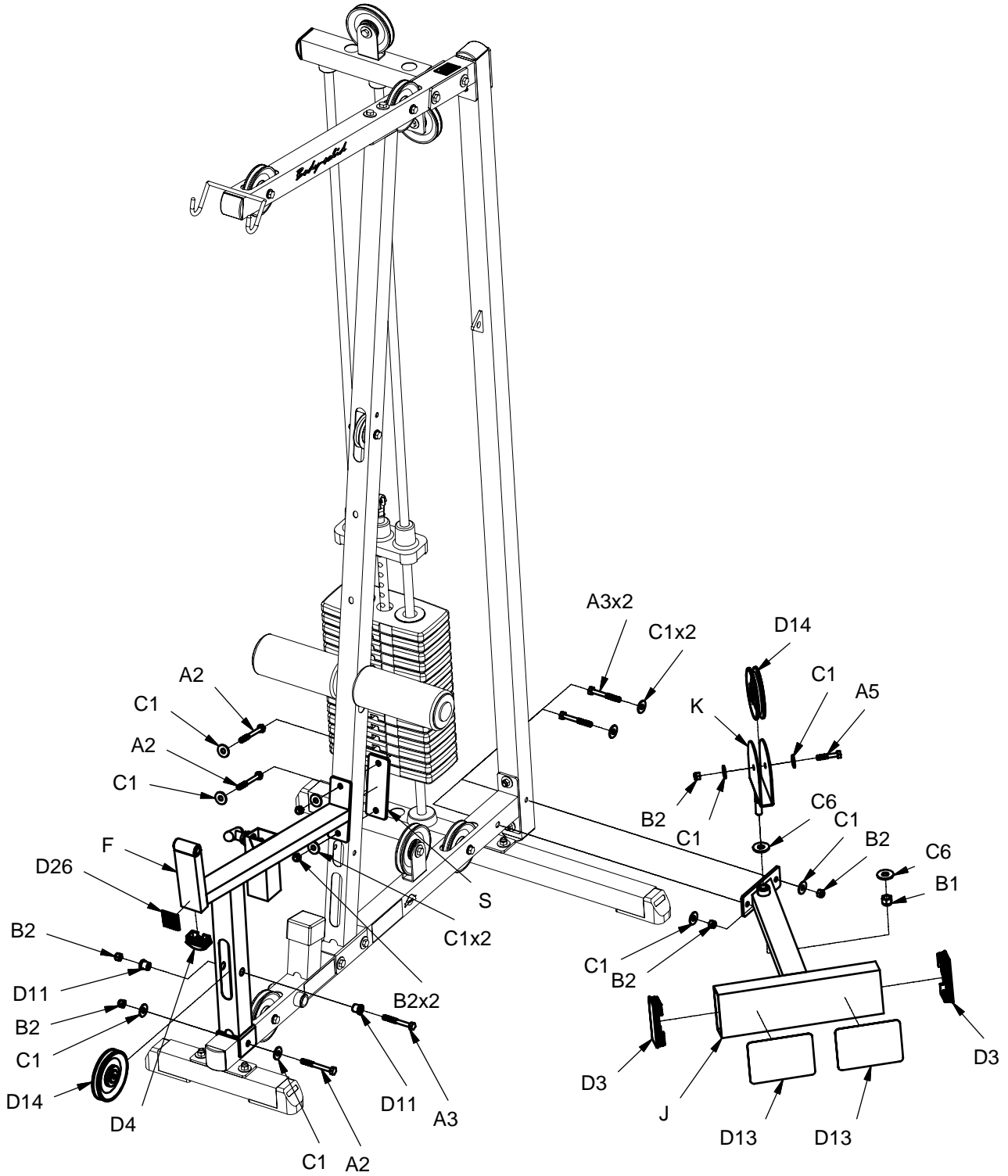

ASSEMBLY- STEP 5

****Note :** Do Not fully tighten frame bolts and nuts until after completing Step 5

****Note :** Do Not fully tighten pulley bolts and nuts until after cable routing

The following Parts and Hardware will be needed to complete Step 5

Parts Description

Hardware Description

<u>Qty</u>	<u>Part</u>	<u>Part Description</u>	<u>Qty</u>	<u>Part</u>	<u>Part Description</u>
1	G	Leg Frame	2	A7	5/16"x2 3/4" hex head bolt
1	H	Seat Frame	2	A8	5/16"x1 1/2" hex head bolt
2	R	Foam Roller Bar	1	A14	1/2"x3 3/4 hex head bolt
1	W	Seat Pad	1	B1	1/2" nylon lock nut
1	X	Back Pad	4	C2	5/16" I.D. washer
			4	C3	5/16" spring washer
			2	C4	1/2" round end cap washer
			2	D1	2"x2"x1.8t round end cap
			2	D4	1"x2" round end cap
			1	D5	1 3/4"x1 3/4" end cap
			4	D6	phi 1" chrome end cap
			4	D16	phi 3 1/2"x8" foam roller
			2	D19	1/2" bolt cap
			6	D25	phi 3" nylon washer

Step by Step

1. Attach (X) - Back Pad to (C) - Angled Support Pillar (note : Do not overtighten pad bolts, overtightening will strip the t-nuts pressed into the wood)
2. Attach (W) - Seat Pad to (H) - Seat Frame (note : Do not overtighten pad bolts, overtightening will strip the t-nuts pressed into the wood)
3. Attach (R) - Foam Roller Bar and 2 (D16) - Foam Rollers to (G) - Leg Frame (note: There are two possible holes to mount (R) Foam Roller Bar to (G) Leg Frame. For taller people (6'-plus) mount in bottom hole, for shorter people (under 6') mount in top hole.)
4. Attach (G) - Leg Frame to (F) - Seat / Extension Frame
5. Attach (R) - Foam Roller Bar and 2 (D16) - Foam Rollers to (H) - Seat Frame
6. Slide (H) - Seat Frame into (F) - Seat / Extension Frame

ASSEMBLY STEP 5

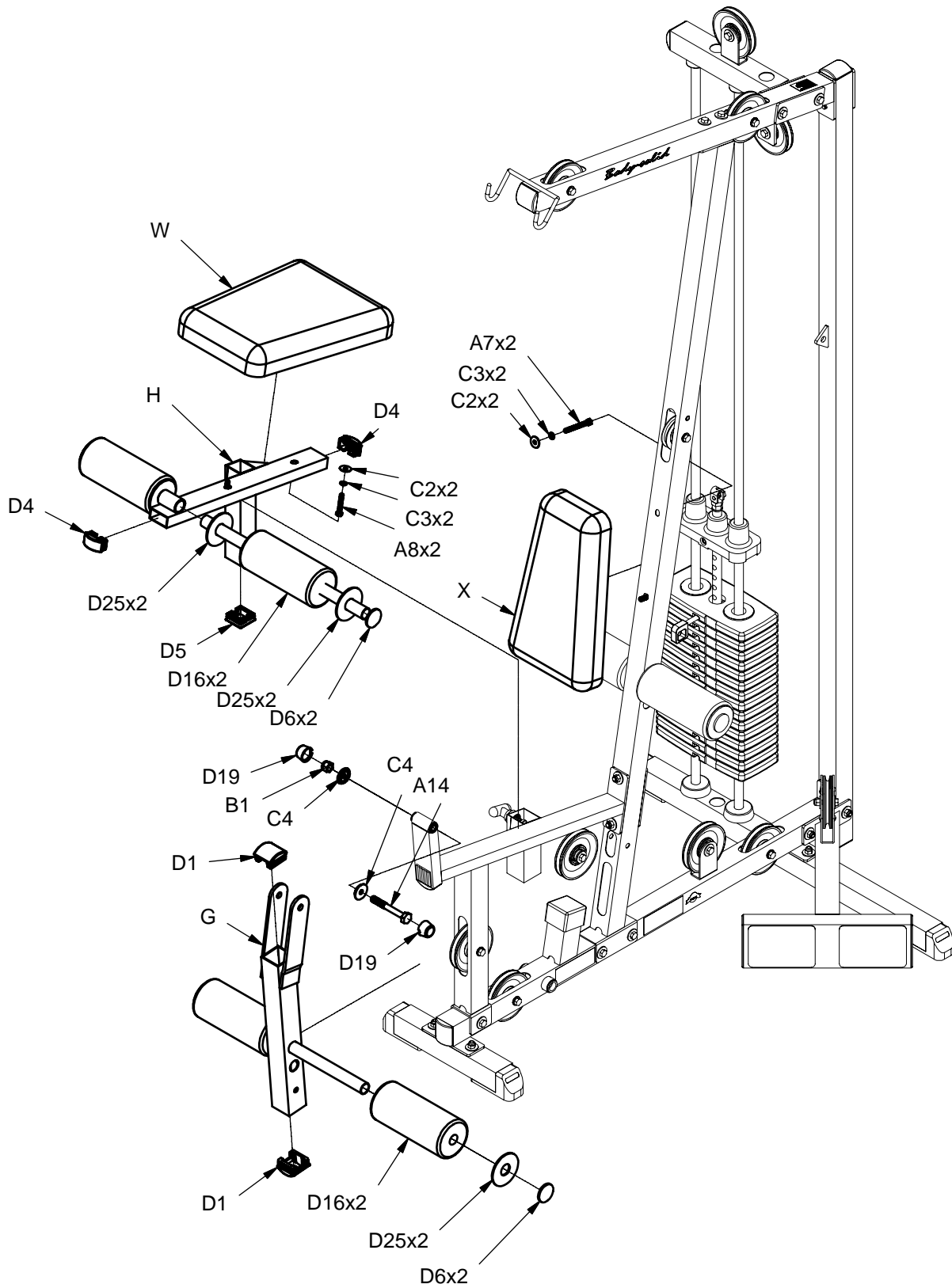

ASSEMBLY- STEP 6

***Note : Do Not fully tighten pulley bolts and nuts until after cable routing*

The following Parts and Hardware will be needed to complete Step 6

Parts Description

<u>Qty</u>	<u>Part</u>	<u>Part Description</u>
1	U	Lat Bar
1	N	Welded Adjustable Double Bracket
2	A5	3/8"x1 3/4" hex head bolt
2	B2	3/8" nylon lock nut
1	D10	Spring snap link
2	D14	4 1/4" pulley
1	D21	lat / stack cable 3235mm
2	D30	Round end cap

Step by Step

1. Begin routing cable (D21) from the housing where the (U) - Lat Bar hangs
2. Route cable over the top of (D) - Top Frame, down through
3. (N) - Welded Adjustable Double Bracket and back up and over (I) - Top Weight Stack Frame as shown
4. When connecting screw end of (D21) - Cable to (D18) - Selector Shaft, ensure that the screw is threaded a minimum of 1/2".

EXM-1500G ASSEMBLY INSTRUCTIONS

ASSEMBLY STEP 6

D21 
Lat Cable

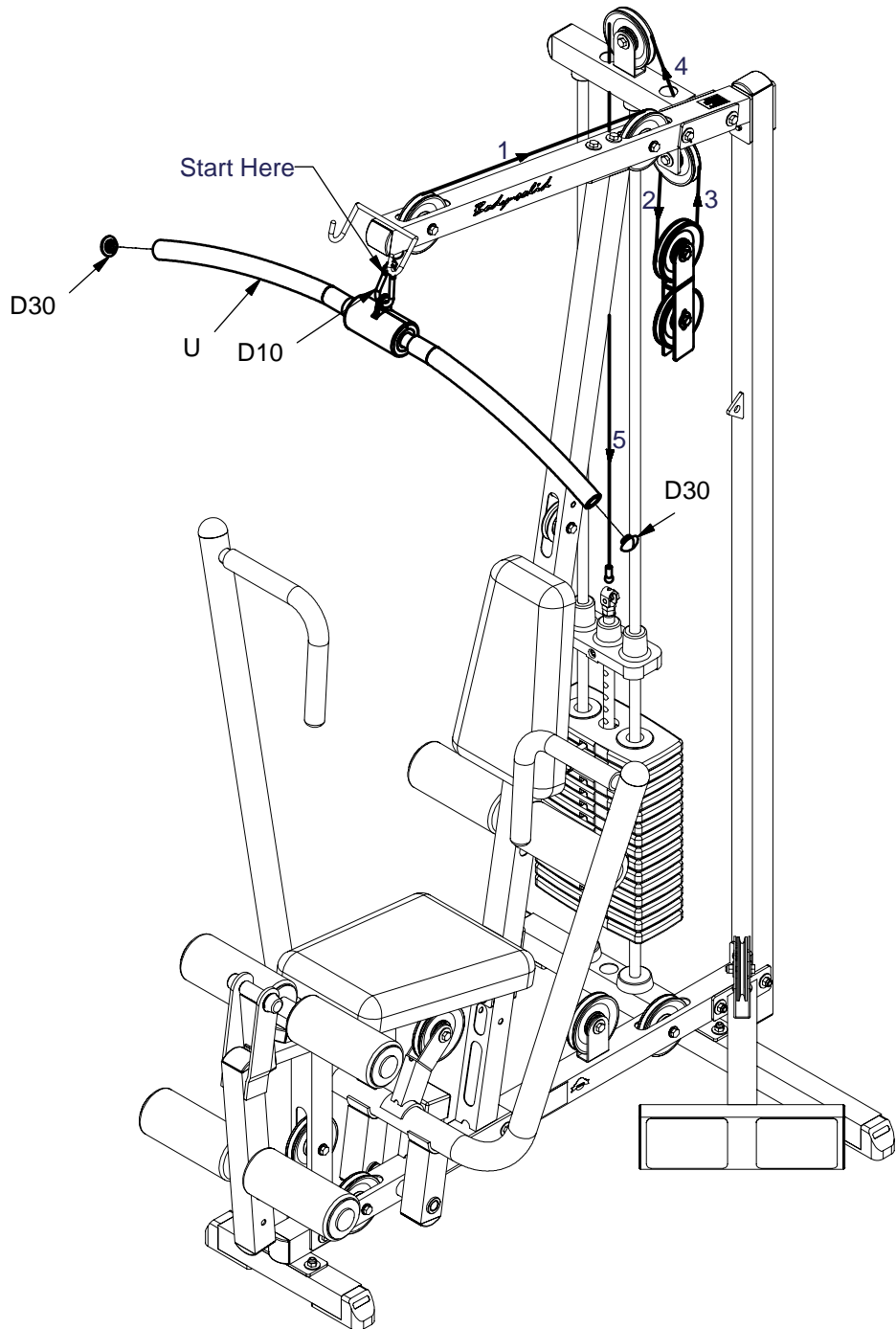

ASSEMBLY- STEP 7

***Note : Do Not fully tighten pulley bolts and nuts until after cable routing*

The following Parts and Hardware will be needed to complete Step 7

Parts Description

<u>Qty</u>	<u>Part</u>	<u>Part Description</u>
1	L	Welded Double Bracket
1	M	Single Pulley Hook
3	A5	3/8"x1 3/4" hex head bolt
3	B2	3/8" nylon lock nut
2	D10	spring snap link
3	D14	4 1/4" pulley
1	D23	ab crunch cable 2210mm

Step by Step

1. Begin routing cable (D23) from the ab crunch housing on (C) - Angled Support Pillar
2. Route cable through (R), (N), and (Q) as shown, connect cable to (B) - Vertical Support Pillar as shown

EXM-1500G ASSEMBLY INSTRUCTIONS

ASSEMBLY STEP 7

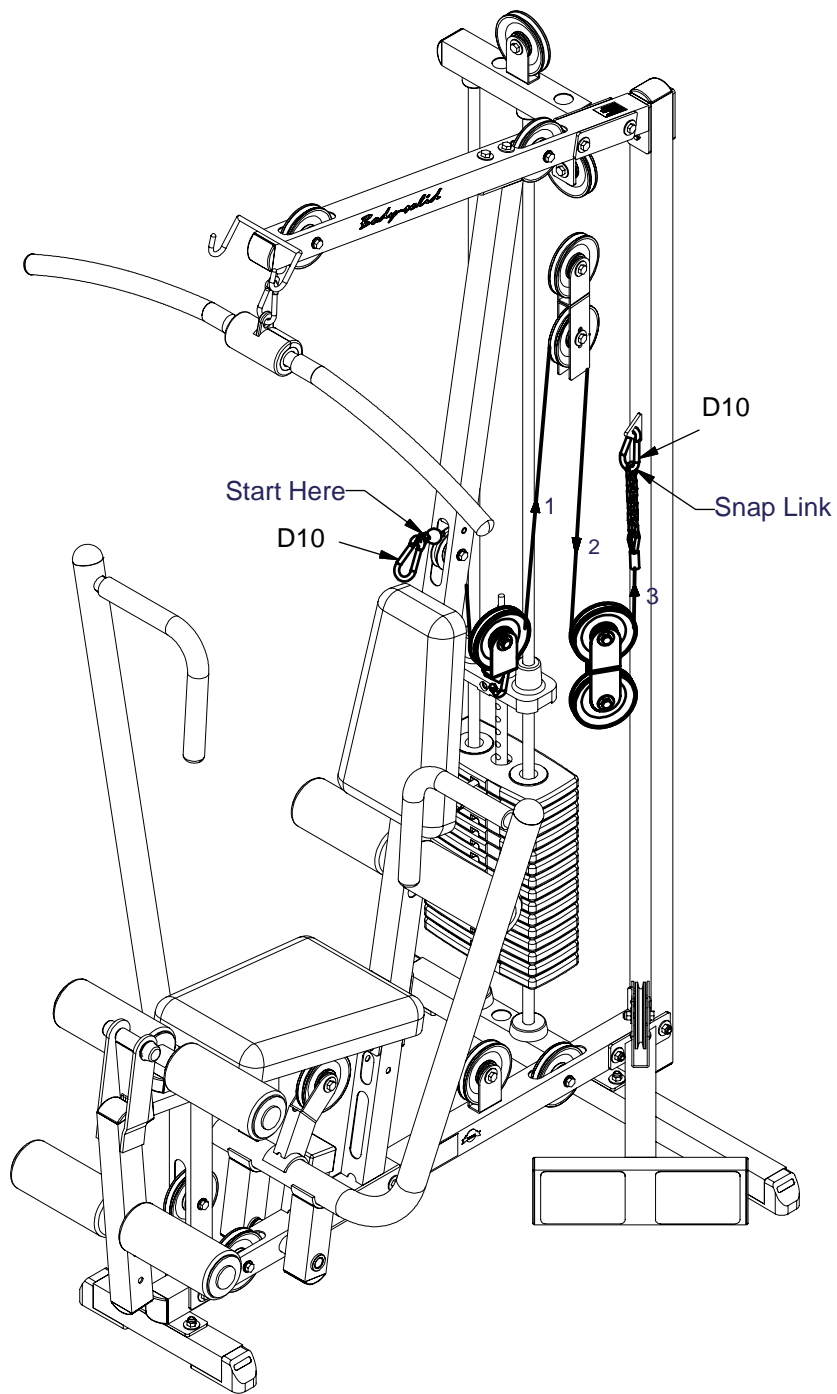

2ND CABLE INSTALL

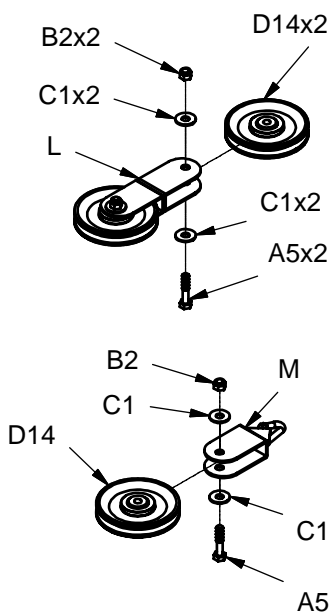

ASSEMBLY- STEP 8

***Note : Do Not fully tighten pulley bolts and nuts involved in this step until after completing this step*

The following Parts and Hardware will be needed to complete Step 9

Parts Description

<u>Qty</u>	<u>Part</u>	<u>Part Description</u>
1	V	Low Row Bar
1	A11	chain
1	A4	3/8"x2 1/2" hex head bolt
1	B2	3/8" nylon lock nut
2	C1	3/8" I.D. washer
2	D10	spring snap links
1	D22	Low row / leg extension cable 3050mm
2	D30	Round end cap

Step by Step

1. Begin routing (D22) - Low Row / Leg Extension Cable at (K) - Low Pulley Bracket, route up through the bottom pulley in (L) - Welded Double Pulley Bracket, down through back pulley mounted in (A) - Main Base Frame, under (A) - Main Base Frame, back up through front pulley mounted in (A) - Main Base Frame and then up and over pulley mounted in (F) - Seat / Extension Frame as shown
2. Attach (D22) - Low Row / Leg Extension Cable to (G) - Leg Frame as shown

EXM-1500G ASSEMBLY INSTRUCTIONS

ASSEMBLY STEP 8

D22 
Low Row
Leg Extension Cable

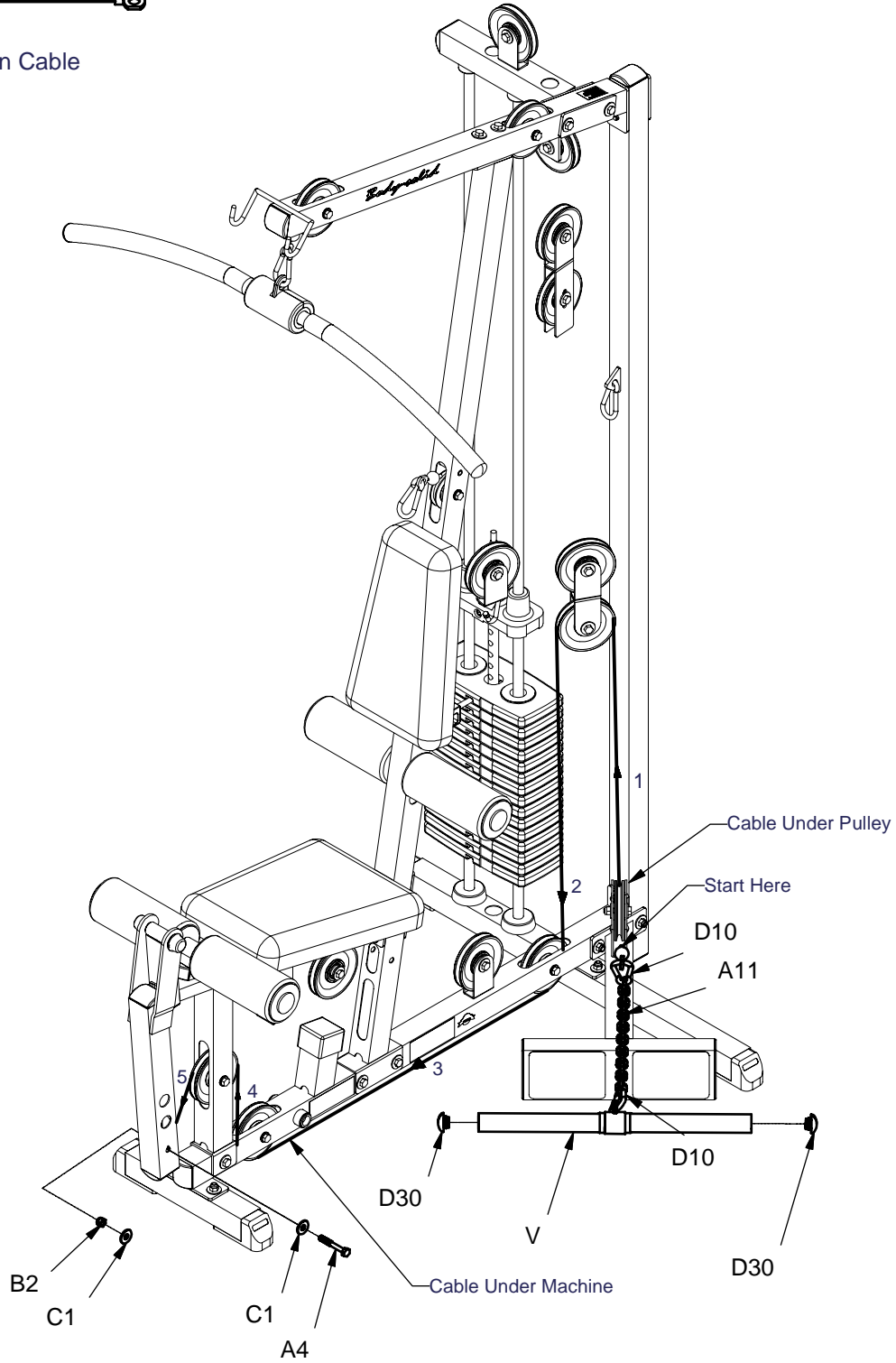

ASSEMBLY- STEP 9

The following Parts and Hardware will be needed to complete Step 8

Parts Description

<u>Qty</u>	<u>Part</u>	<u>Part Description</u>
1	A4	3/8"x2 1/2" hex head bolt
1	B2	3/8" nylon lock nut
2	C1	3/8" I.D. washer
1	D20	Chest press cable 1440mm

Step by Step

1. Attach (D20) - Chest Press Cable to (C) - Angled Support Pillar
2. Route cable through pulley mounted on (E) - Bench Press Frame down through pulley mounted on (A) - Main Base Frame and connect to hook on (M) - Single Pulley Hook as shown

EXM-1500G ASSEMBLY INSTRUCTIONS

ASSEMBLY STEP 9

D20  
Bench Press
Cable

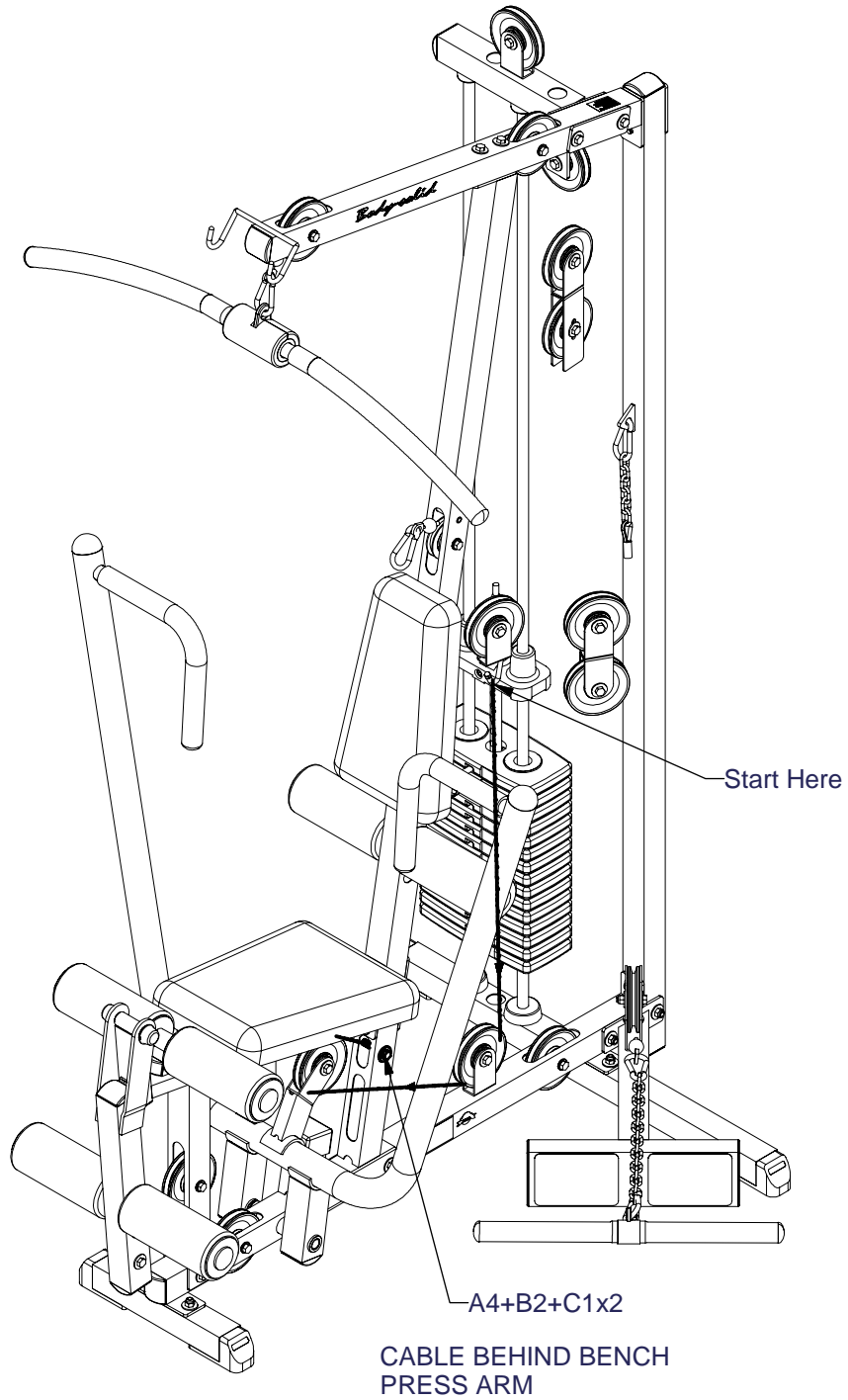

CABLE ADJUSTMENTS

After Cable Install 3
Diffrent Forms of Adjustment
After Cables Are Completed

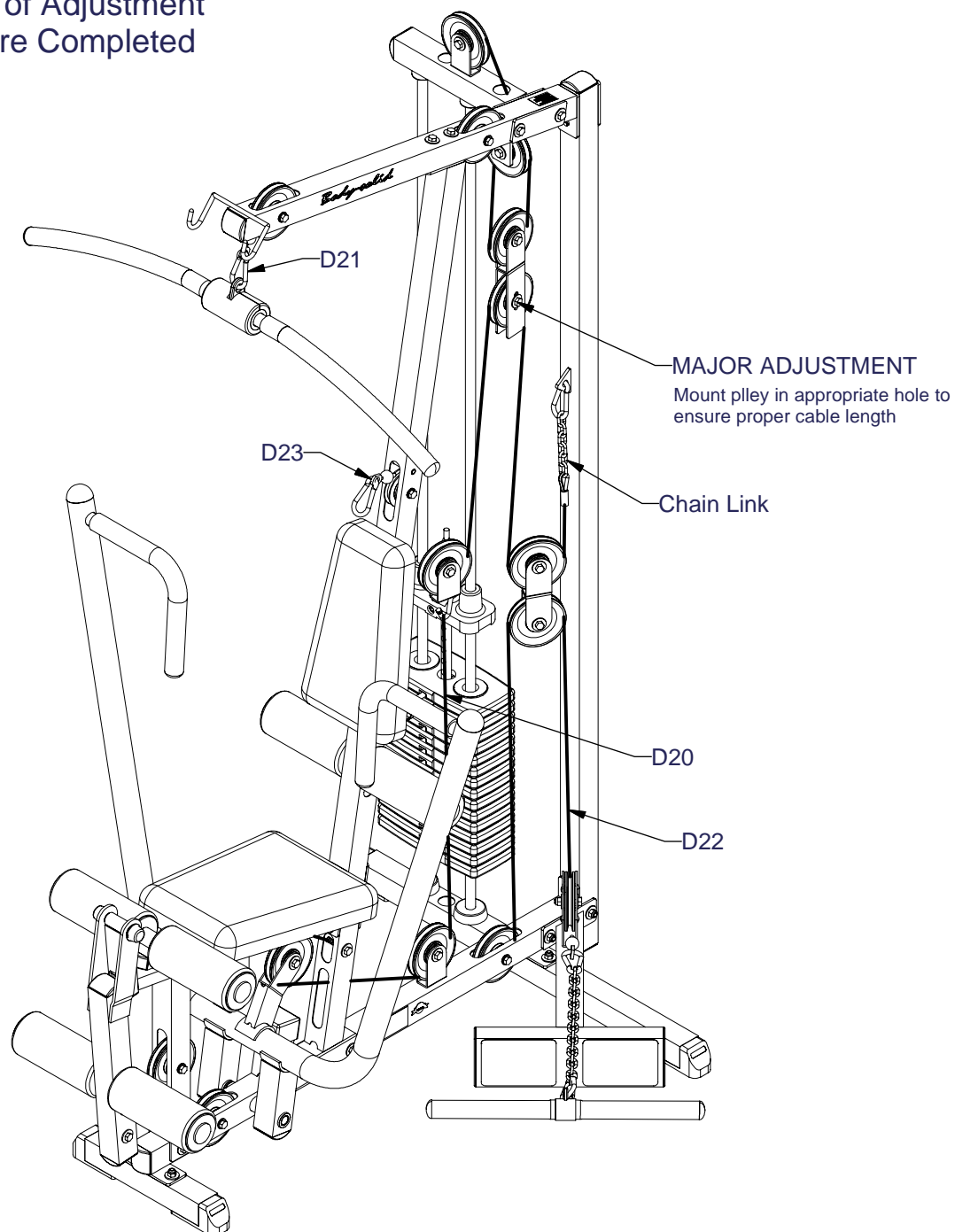

INSPECTIONS AND MAINTENANCE SCHEDULE

There is a risk assumed by individuals who use this type of equipment. To minimize risk, follow the rules below.

Inspect equipment daily, ensuring that all nuts, bolts and screws are fully tightened.

Inspect cables daily ensuring they are routed properly and not worn, frayed or stretched. Check and adjust tension on cables daily.

When using pop-pin adjustments, always make sure the plunger for the pop-pin is securely inserted into and adjustment hole.

Before performing any exercise, always make sure all ball-pins, ring-pins, pop-pins and selector pins are inserted properly and all snap-links are properly closed.

Replace worn parts immediately.

Human perspiration is corrosive. Clean your machine regularly. Wipe down and dry upholstery and frame pieces on a daily basis.

Every week clean the chrome guide rods with a dry cloth and apply a coat of dry silicon spray or teflon based spray lubricant.

Every week clean and lubricate all non-chrome guide rods and all seat posts and adjustments for starting positions.

Every week check hand grips, rollers and non-skid surfaces for wear.

Only use Body-Solid parts. Parts from other manufacturers or any other modifications will void the warranty and may result in serious injury.

Do not use this machine with damaged, worn or missing parts.

If there is any doubt about the ability of this equipment to operate safely, do not use the equipment until it is serviced.

Please ensure that all warning stickers are visible and acknowledged by users of the equipment.

Failure to follow these rules may result in serious injury. If unsure about the proper use of the machine, consult your local Body-Solid distributor or call the Body-Solid Customer Service department at 1-800-556-3113.