

ASSEMBLY INSTRUCTIONS FOR THE DF9000 FLAT / INCLINE BENCH

650 LB CAPACITY WEIGHT
AND USER

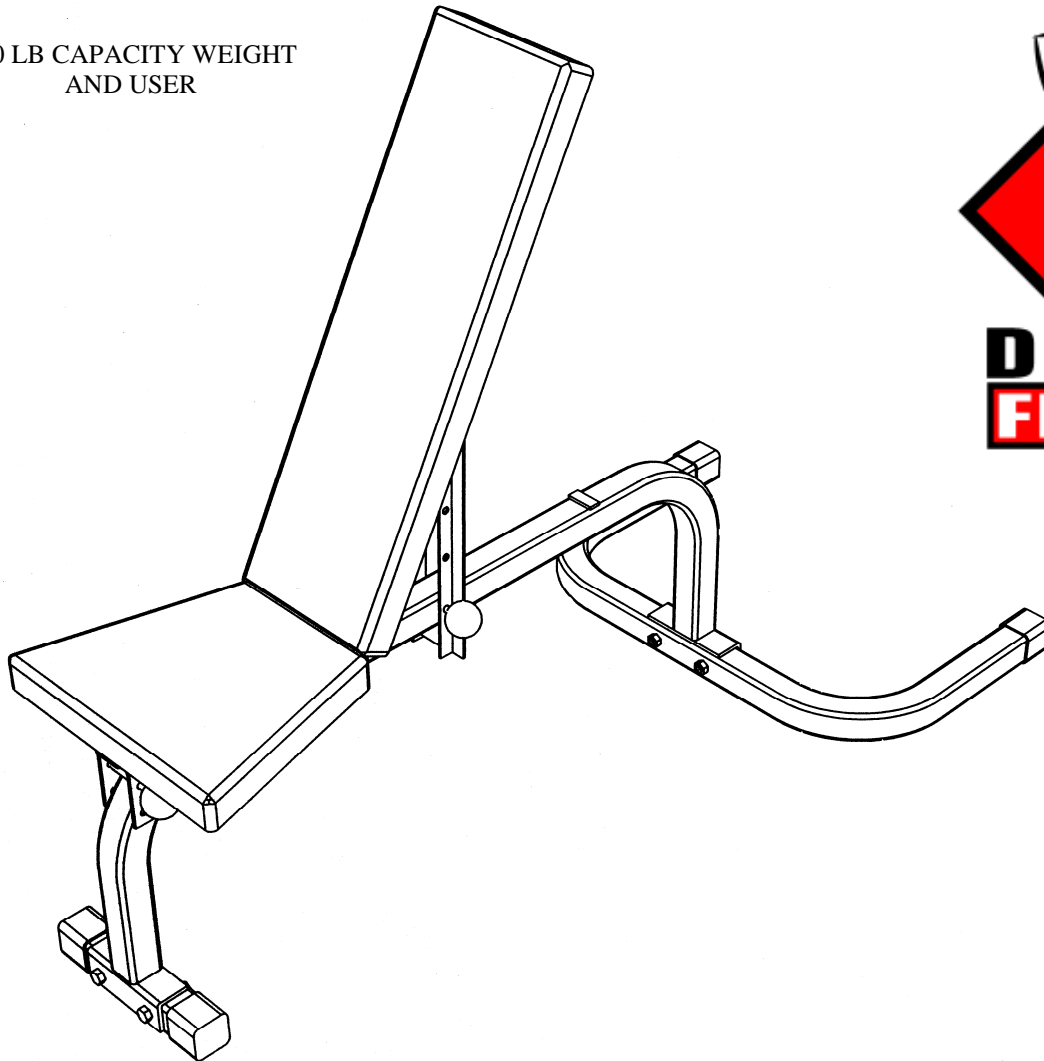

(888) 258-0533

FOR YOUR SAFETY READ ALL INSTRUCTIONS CAREFULLY

*NOTE IF YOU ARE MISSING HARDWARE OR HAVE ANY FIT UP PROBLEMS PLEASE CONTACT DELTECH FITNESS TOLL FREE (888) 258-0533

BOX CONTENTS

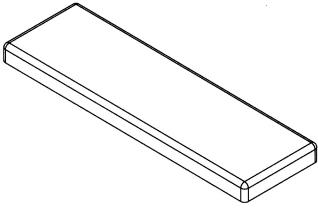

A
BACKREST
QTY 1

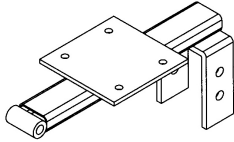

B
SEAT SUPPORT
QTY 1

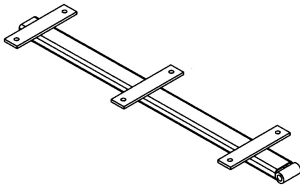

C
BACK SUPPORT
QTY 1

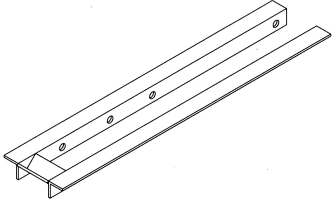

D
INCLINE SUPPORT
QTY 1

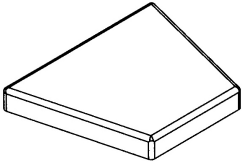

E
SEAT
QTY 1

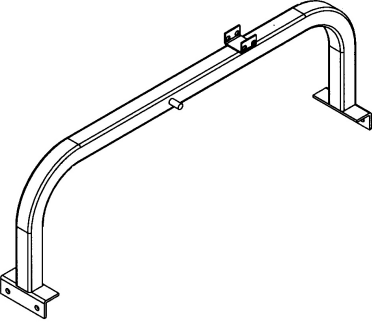

F
FRAME
QTY 1

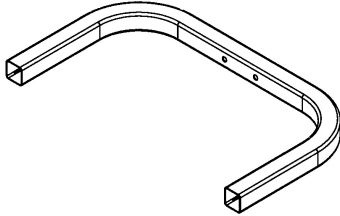

G
REAR FOOT
QTY 1

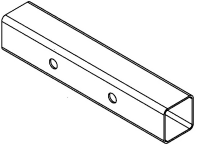

H
FRONT FOOT
QTY 1

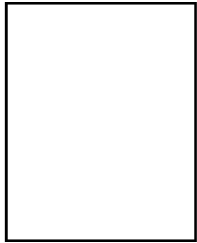

DF9000
INSTRUCTION
SHEET
QTY 1

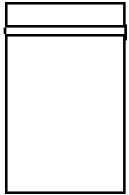

DF9000
HARDWARE PACK
QTY 1

IF YOU ARE MISSING PARTS PLEASE CALL 1-888-258-0533

HARDWARE

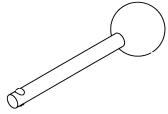

I
SEAT SUPPORT
PIN
QTY 2

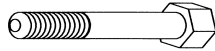

J
M12 x 80MM
BOLT
QTY 2

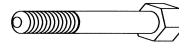

K
M10 x 70MM
BOLT
QTY 5



L
M6 x 25MM
BOLT
QTY 10

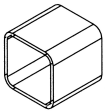

M
RUBBER
SHOE
QTY 4



N
M12 WASHER
QTY 4



O
M10 WASHER
QTY 4



P
M6 WASHER
QTY 10



Q
M12 LOCKNUT
QTY 2



R
M10 LOCKNUT
QTY 5

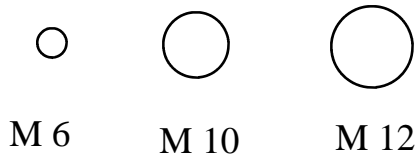

BOLT DIAMETER



MEASURE BOLT LENGTH HERE

(888) 258-0533

FOR YOUR SAFETY READ ALL INSTRUCTIONS CAREFULLY

*NOTE IF YOU ARE MISSING HARDWARE OR HAVE ANY FIT UP PROBLEMS PLEASE CONTACT DELTECH FITNESS TOLL FREE (888) 258-0533

SEAT & BACKREST ASSEMBLY

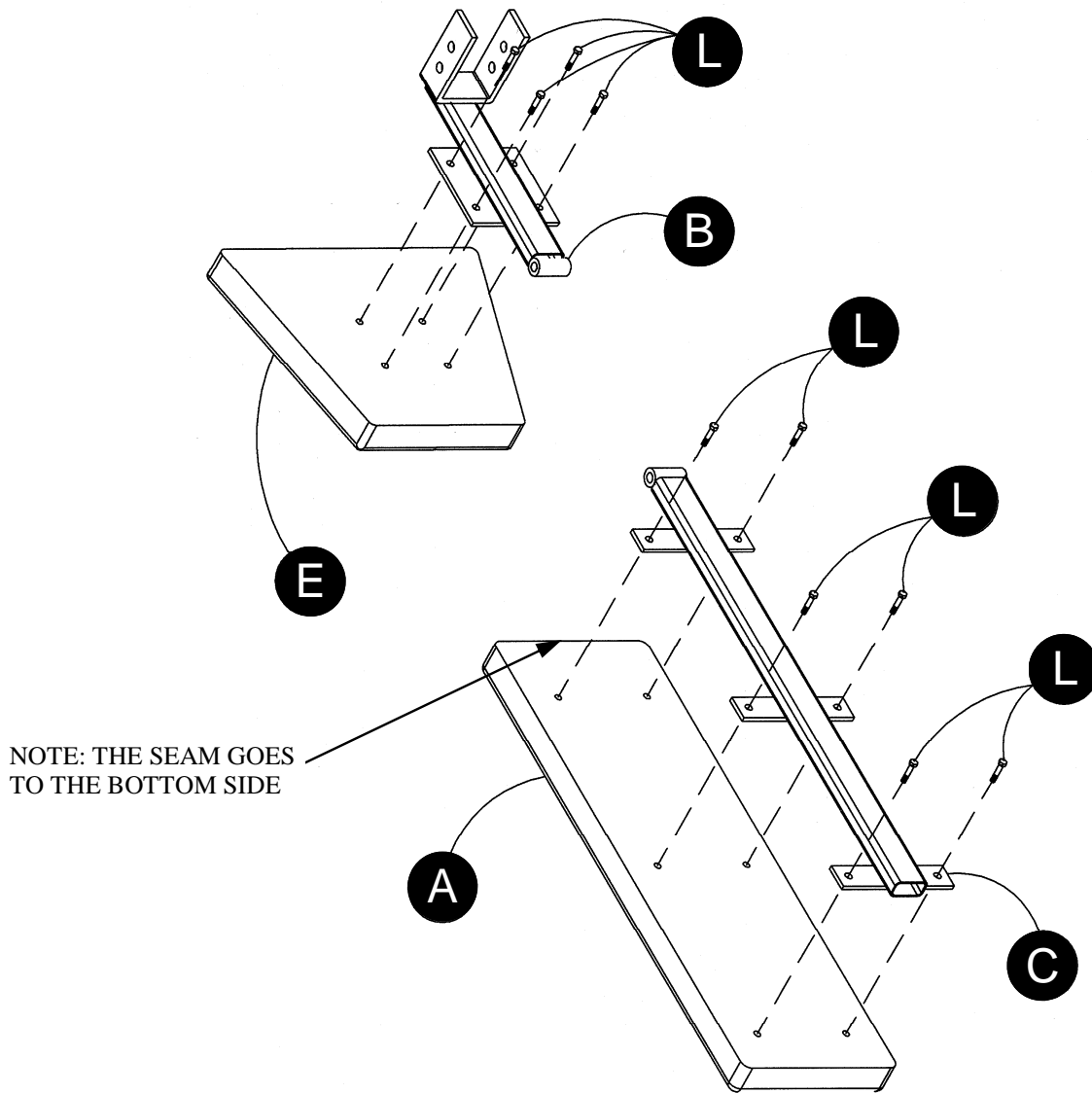

NOTE: THE SEAM GOES TO THE BOTTOM SIDE

USE WASHERS ON ALL BOLTS IN THIS DIAGRAM

TOOLS REQUIRED:
WRENCHES OR METRIC SOCKET SET

USING M6 x 25MM BOLTS (L) ASSEMBLE THE BACKREST SUPPORT (C) TO THE BACKREST (A) (*NOTE THE SEAM GOES TOWARD THE BOTTOM SIDE) AND THE SEAT SUPPORT (B) TO THE SEAT (E).

FRAME ASSEMBLY

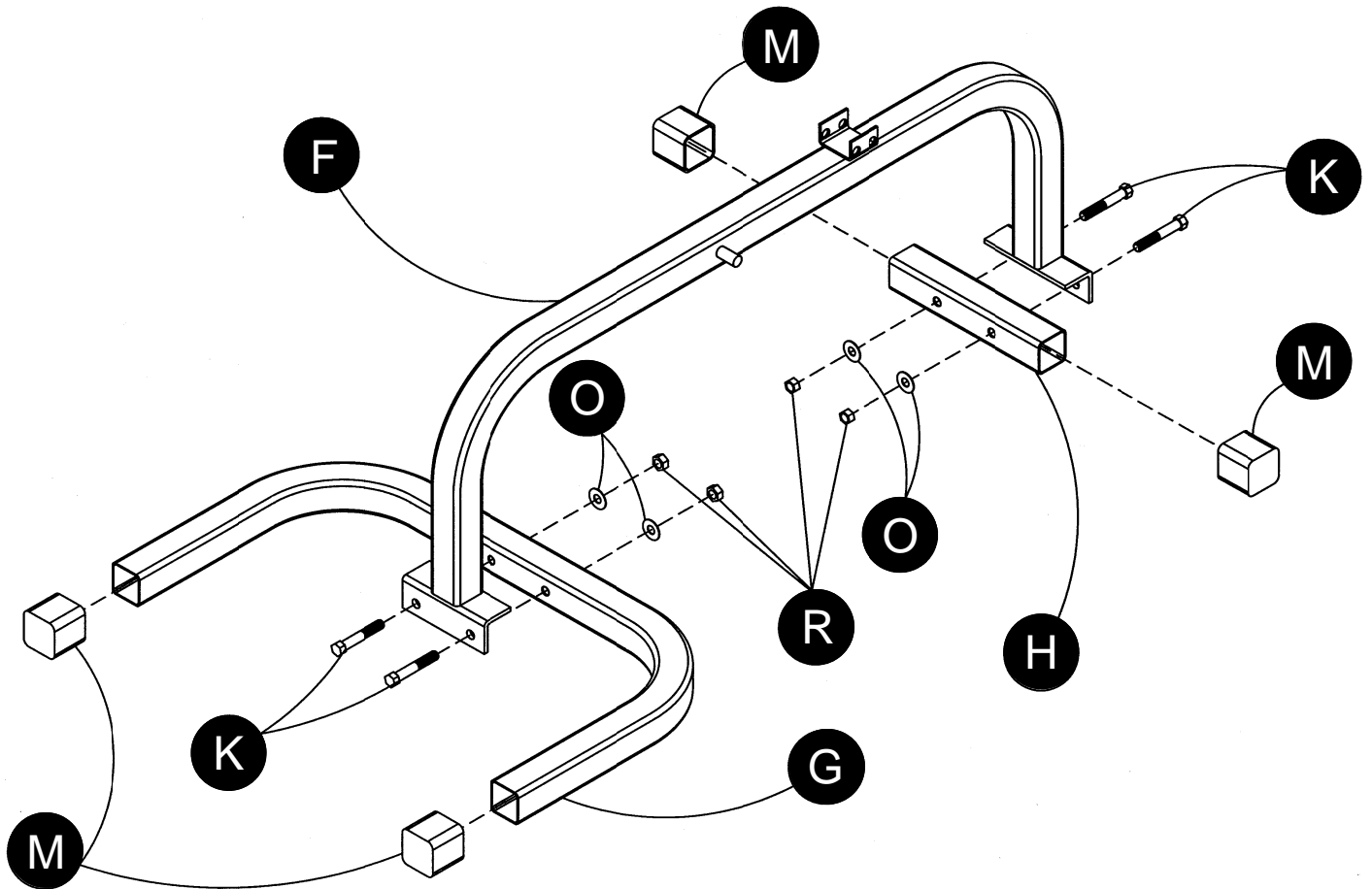

BOLT THE FRONT FOOT (H) TO THE FRAME (F) AND THE BACK FOOT (G) TO THE FRAME (F) USING THE M10 x 70MM BOLTS (K), THE M10 LOCK NUTS (R), AND THE M10 FLAT WASHER (O).

NEXT SLIDE THE RUBBER SHOES (M) ONTO THE FRONT FOOT (H) AND THE BACK FOOT (G).

(NOTE: THE NUTS USED ON THIS BENCH ARE LOCK NUTS, THIS MEANS YOU MUST TIGHTEN THEM DOWN PAST THE PLASTIC INSERT.) YOU MUST USE A WRENCH TO TIGHTEN!

SEAT & BACKREST INSTALLATION

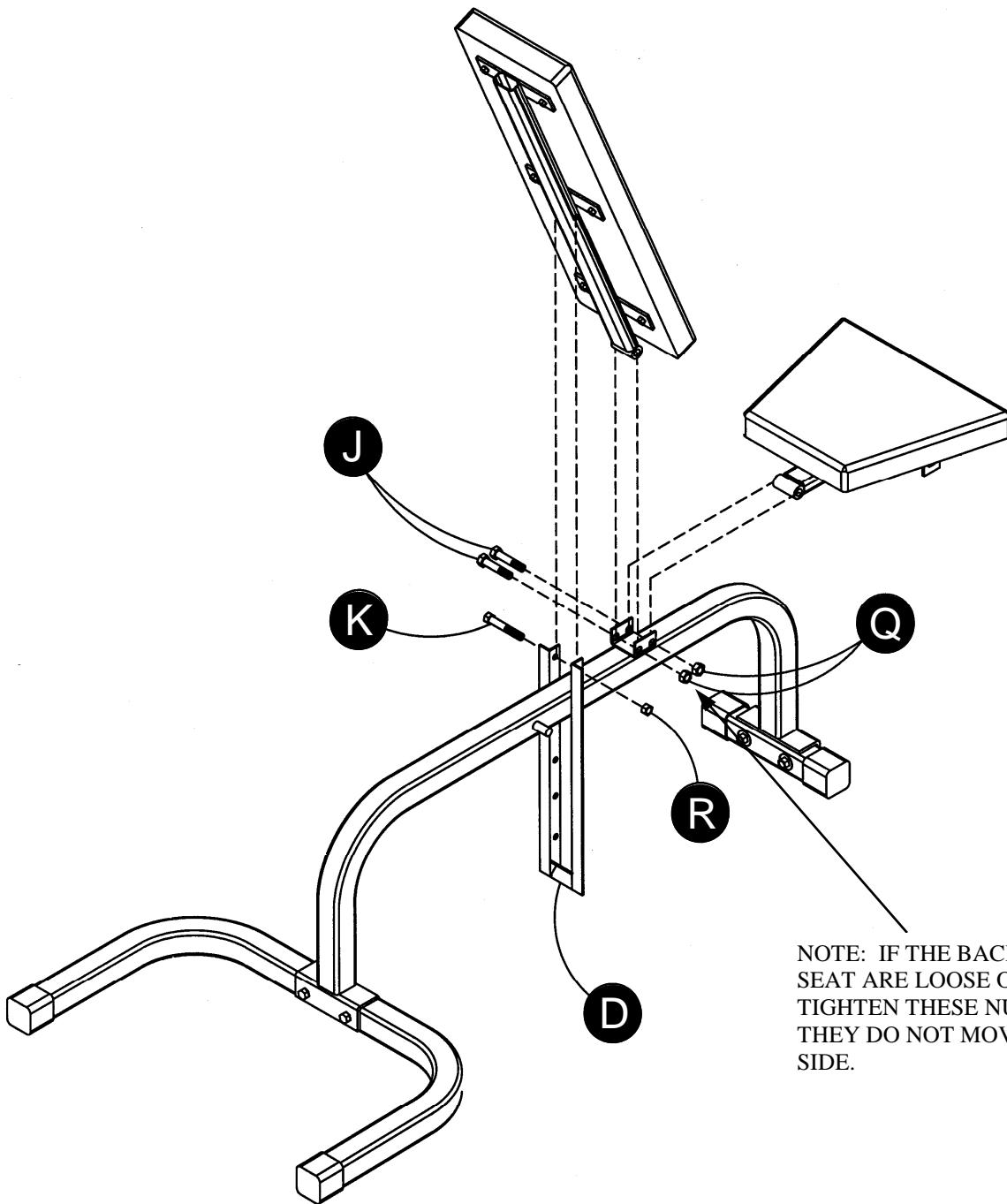

NOTE: IF THE BACKREST OR SEAT ARE LOOSE OR WOBBLE TIGHTEN THESE NUTS UNTIL THEY DO NOT MOVE SIDE TO SIDE.

ATTACH THE THE BACKREST ASSEMBLY AND THE SEAT ASSEMBLY TO THE BODY USING THE M12 x 80MM BOLTS (J), THE M12 FLAT WASHERS(N), AND THE M12 LOCK NUTS (Q). * **THE TIGHTER YOU MAKE THESE BOLTS THE MORE STABLE THE BENCH WILL GET.** (NOTE: **THE LOCK PIN FOR THE SEAT IS NOT NEEDED IN THE FLAT POSITION.**)

NEXT ATTACH THE INCLINE SUPPORT (D) TO THE BACKREST ASSEMBLY USING THE THE M10 x 70MM BOLT, THE M10 FLAT WASHERS, (O) AND THE M10 LOCKNUT NUT (R). USE THE SEAT SUPPORT PIN SUPPLIED TO ADJUST THE INCLINE.

MAKE SURE ALL BOLTS ARE BEFORE USE. CHECK THE BOLTS PERIODICALLY AND TIGHTEN AS NEEDED.

(NOTE: **THE NUTS USED ON THIS BENCH ARE LOCK NUTS, THIS MEANS YOU MUST TIGHTEN THEM DOWN PAST THE PLASTIC INSERT.**) **YOU MUST USE A WRENCH TO TIGHTEN!**

ADJUSTMENT

ADJUSTING THE BACK PAD: RAISE AND LOWER THE BACKREST USING THE LOCK PIN. MAKE SURE THE LOCK PIN IS COMPLETELY THROUGH THE BACKREST BRACKET AND ADJUSTMENT HOLE BEFORE USE.

ADJUSTING THE SEAT PAD: RAISE THE SEAT PAD TO THE DESIRED POSITION BY USING THE LOCK PIN THROUGH THE HOLES IN THE BRACKET. (NOTE: THE LOCK PIN IS NOT NEEDED IN THE FLAT POSITION.)

SAFETY NOTICE

WARNING: THE USER OF THIS WEIGHT EQUIPMENT ASSUMES THE POSSIBILITY OF INJURY BY EXERCISING ON THIS EQUIPMENT. THE POSSIBILITY OF RISK CAN BE REDUCED BY ALWAYS FOLLOWING THESE SIMPLE RULES:

- 1) BEFORE BEGINNING ANY EXERCISE PROGRAM, CONSULT YOUR DOCTOR FOR A COMPLETE PHYSICAL EXAMINATION AND SUGGESTED EXERCISE PROGRAM SPECIFIC FOR YOU.
- 2) STRETCH BEFORE AND AFTER THE EXERCISE PROGRAM, PROPER STRETCHING WILL PREPARE YOUR JOINTS AND MUSCLES FOR EXERCISE AND HELP AVOID INJURIES.
- 3) IF AT ANY TIME YOU SHOULD FEEL FAINT OR DIZZY, NAUSEOUS OR EXPERIENCE ANY OTHER ABNORMAL SYMPTOMS OR DISCOMFORT, DISCONTINUE USE AND CONSULT YOUR DOCTOR.
- 4) DO NOT USE THIS EQUIPMENT WITHOUT QUALIFIED SUPERVISION AND PROPER TRAINING NEVER WORK OUT ALONE ALWAYS HAVE A PARTNER.
- 5) SECURELY TIGHTEN ALL BOLTS AND REGULARLY CHECK TO ENSURE ALL BOLTS HAVE NOT LOOSENED.
- 6) WEAR GOOD RUBBER SOLE SHOES ONLY DO NOT USE BARE FOOTED OR WITH SOCKS ONLY.
- 7) DO NOT WEAR LOOSE CLOTHES SUCH AS ROBES, GOWNS, PANTS, LONG SHIRTS OR JEWELRY WHICH COULD BECOME ENTANGLED IN MOVING PARTS.
- 8) DO NOT STAND OR KNEEL ON SEAT ALWAYS SIT OR LAY SQUARELY CENTERED.
- 9) KEEP HEAD, LIMBS AND BODY PARTS CLEAR OF MOVING PARTS AND WEIGHT PLATES.
- 10) CHILDREN SHOULD NOT USE EXERCISE EQUIPMENT WITHOUT SUPERVISION BECAUSE OF POSSIBILITY OF INJURY FROM IMPROPER USAGE. THIS EQUIPMENT IS INTENDED FOR HOME USE ONLY.
- 11) REPLACEMENT OR WORN OR DEFECTIVE PARTS MUST BE REPLACED WITH FACTORY AUTHORIZED PARTS. IF OTHER THAN FACTORY AUTHORIZED PARTS OR ASSESSORS ARE USED ALL WARRANTIES AND LIABILITIES BECOME VOID.

T-SHIRT ORDER FORM

DELTECH FITNESS T - SHIRT

SIZES AVAILABLE ARE M-XXL. THE COLOR OF THE SHIRTS ARE WHITE. RED AND BLACK LOGO. ONLY \$12.99



DELTECH FITNESS MUSCLE SHIRT

SIZES AVAILABLE M-XXL THE COLOR AVAILABLE IS BLACK. RED AND WHITE LOGO. ONLY \$12.99



SEND TO: DELTECH MANUFACTURING, INC.
3910 OAKLAWN DR.
LOUISVILLE, KY. 40219

ALL ORDERS SHIPPED UPS GROUND.

MAKE CHECK OR MONEY ORDER PAYABLE TO: DELTECH MANUFACTURING
KENTUCKY RESIDENTS ADD 6% SALES TAX. ALLOW 3 WEEKS FOR DELIVERY.
PRICE INCLUDES SHIPPING TO THE CONTIGUOUS UNITED STATES
OR ORDER ONLINE WITH A CREDIT CARD AT WWW.FITNESSDESTINATION.COM

QTY	SIZE	DESCRIPTION	COLOR	PRICE	TOTAL
		T - SHIRT	WHITE	\$12.99 EA.	
		MUSCLE SHIRT	BLACK	\$12.99 EA.	
				TOTAL	

SHIPPING INFORMATION:
