

ASSEMBLY INSTRUCTIONS FOR THE DF516 DUMBBELL RACK

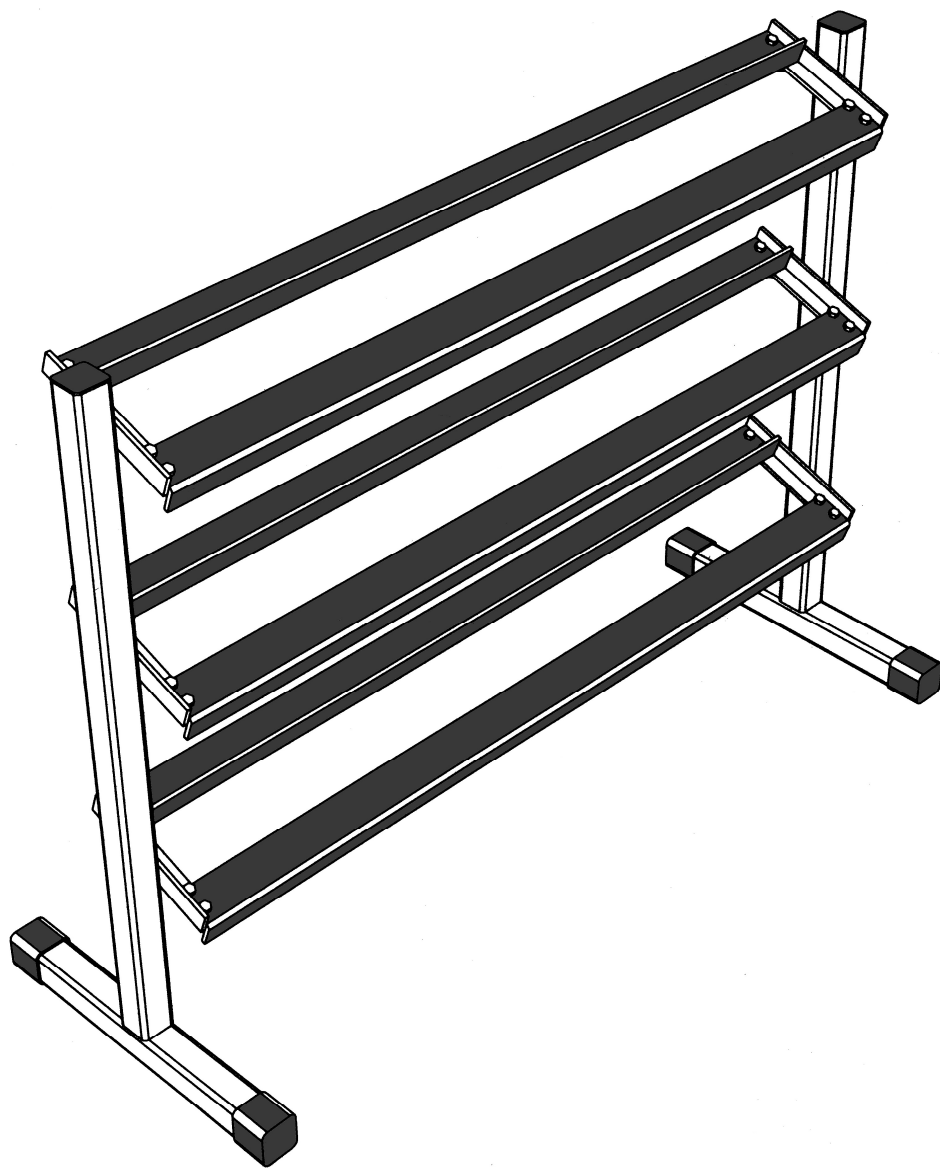

(888) 258-0533

FOR YOUR SAFETY READ ALL INSTRUCTIONS CAREFULLY

*NOTE IF YOU ARE MISSING HARDWARE OR HAVE ANY FIT UP PROBLEMS PLEASE CONTACT DELTECH FITNESS TOLL FREE (888) 258-0533

BOX CONTENTS

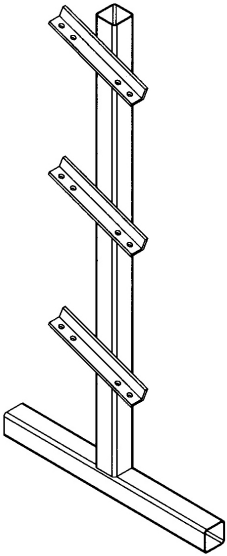

A
L.H. LEG
QTY 1

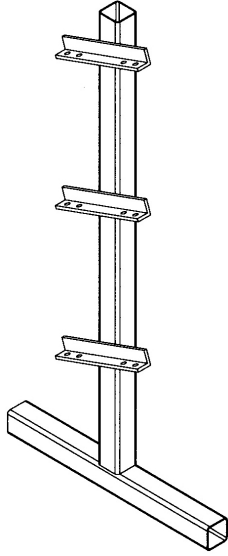

B
R.H. LEG
QTY 1

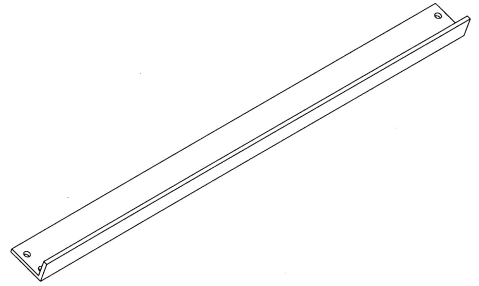

C
CROSSMEMBER
QTY 4



DF515
HARDWARE PACK
QTY 1



DF515
INSTRUCTION SHEET
QTY 1



*NOTE IF YOU ARE MISSING HARDWARE OR HAVE ANY FIT UP PROBLEMS PLEASE CONTACT DELTECH FITNESS TOLL FREE (888) 258-0533

HARDWARE



R

**2" SQUARE CAP
QTY 2**

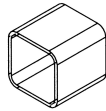

S

**RUBBER SHOE
QTY 4**

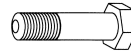

T

**M10 x 25MM BOLT
QTY 24**



U

**M10 LOCKNUT
QTY 24**



*NOTE IF YOU ARE MISSING HARDWARE OR HAVE ANY FIT UP PROBLEMS PLEASE CONTACT DELTECH FITNESS TOLL FREE (888) 258-0533

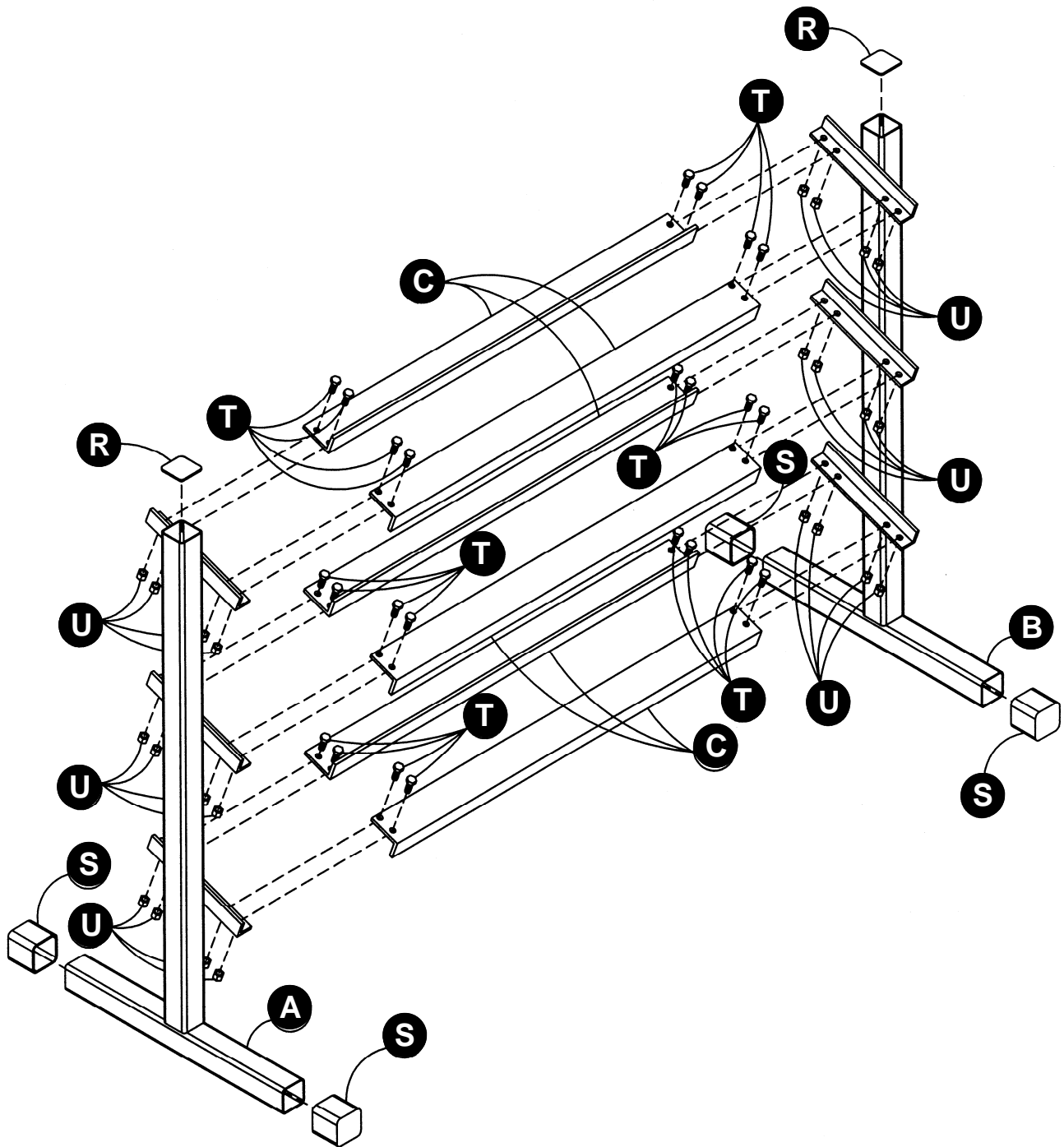

TOOLS REQUIRED:

9/16" WRENCH

ATTACH THE UPRIGHTS (A) & (B) TO THE CROSS MEMBERS (C) USING THE M10 x 25MM BOLTS (T) AND M10 LOCKNUTS (U).

INSTALL 2" SQUARE CAPS (R) AND RUBBER SHOES (S).

MAKE MAKE SURE ALL BOLTS ARE TIGHT BEFORE USE.

SAFETY NOTICE

WARNING: THE USER OF THIS WEIGHT EQUIPMENT ASSUMES THE POSSIBILITY OF INJURY BY EXERCISING ON THIS EQUIPMENT. THE POSSIBILITY OF RISK CAN BE REDUCED BY ALWAYS FOLLOWING THESE SIMPLE RULES:

- 1) BEFORE BEGINNING ANY EXERCISE PROGRAM, CONSULT YOUR DOCTOR FOR A COMPLETE PHYSICAL EXAMINATION AND SUGGESTED EXERCISE PROGRAM SPECIFIC FOR YOU.
- 2) STRETCH BEFORE AND AFTER THE EXERCISE PROGRAM. PROPER STRETCHING WILL PREPARE YOUR JOINTS AND MUSCLES FOR EXERCISE AND HELP AVOID INJURIES.
- 3) IF AT ANY TIME YOU SHOULD FEEL FAINT OR DIZZY, NAUSEOUS OR EXPERIENCE ANY OTHER ABNORMAL SYMPTOMS OR DISCOMFORT DISCONTINUE USE AND CONSULT YOUR DOCTOR.
- 4) DO NOT USE THIS EQUIPMENT WITHOUT QUALIFIED SUPERVISION AND PROPER TRAINING. NEVER WORK OUT ALONE- ALWAYS HAVE A PARTNER.
- 5) SECURELY TIGHTEN ALL BOLTS AND REGULARLY CHECK TO ENSURE ALL BOLTS HAVE NOT LOOSENED.
- 6) WEAR GOOD RUBBER SOLE SHOES ONLY. DO NOT USE BARE FOOTED OR WITH SOCKS ONLY.
- 7) DO NOT WEAR LOOSE CLOTHES SUCH AS ROBES, GOWNS, PANTS, LONG SHIRTS OR JEWELRY WHICH COULD BECOME ENTANGLED IN MOVING PARTS.
- 8) DO NOT STAND OR KNEEL ON SEAT. ALWAYS SIT OR LAY SQUARELY CENTERED.
- 9) KEEP HEAD, LIMBS AND BODY PARTS CLEAR OF MOVING PARTS AND WEIGHT PLATES.
- 10) CHILDREN SHOULD NOT USE EXERCISE EQUIPMENT WITHOUT SUPERVISION BECAUSE OF POSSIBILITY OF INJURY FROM IMPROPER USAGE. THIS EQUIPMENT IS INTENDED FOR HOME USE ONLY.
- 11) REPLACEMENT OF WORN OR DEFECTIVE PARTS MUST BE WITH FACTORY AUTHORIZED PARTS. IF OTHER THAN FACTORY AUTHORIZED PARTS OR ASSESSORS ARE USED ALL WARRANTIES AND LIABILITIES BECOME VOID.

T-SHIRT ORDER FORM

DELTECH FITNESS T - SHIRT

SIZES AVAILABLE ARE M-XXL. THE COLOR OF THE SHIRTS ARE WHITE. RED AND BLACK LOGO. ONLY \$12.99



DELTECH FITNESS MUSCLE SHIRT

SIZES AVAILABLE M-XXL THE COLOR AVAILABLE IS BLACK. RED AND WHITE LOGO. ONLY \$12.99



SEND TO: DELTECH MANUFACTURING, INC.
3910 OAKLAWN DR.
LOUISVILLE, KY. 40219

ALL ORDERS SHIPPED UPS GROUND.

MAKE CHECK OR MONEY ORDER PAYABLE TO: DELTECH MANUFACTURING
KENTUCKY RESIDENTS ADD 6% SALES TAX. ALLOW 3 WEEKS FOR DELIVERY.
PRICE INCLUDES SHIPPING TO THE CONTIGUOUS UNITED STATES
OR ORDER ONLINE WITH A CREDIT CARD AT WWW.FITNESSDESTINATION.COM

QTY	SIZE	DESCRIPTION	COLOR	PRICE	TOTAL
		T - SHIRT	WHITE	\$12.99 EA.	
		MUSCLE SHIRT	BLACK	\$12.99 EA.	
				TOTAL	

SHIPPING INFORMATION:
