

ASSEMBLY INSTRUCTIONS FOR THE DF511 DUMBBELL RACK

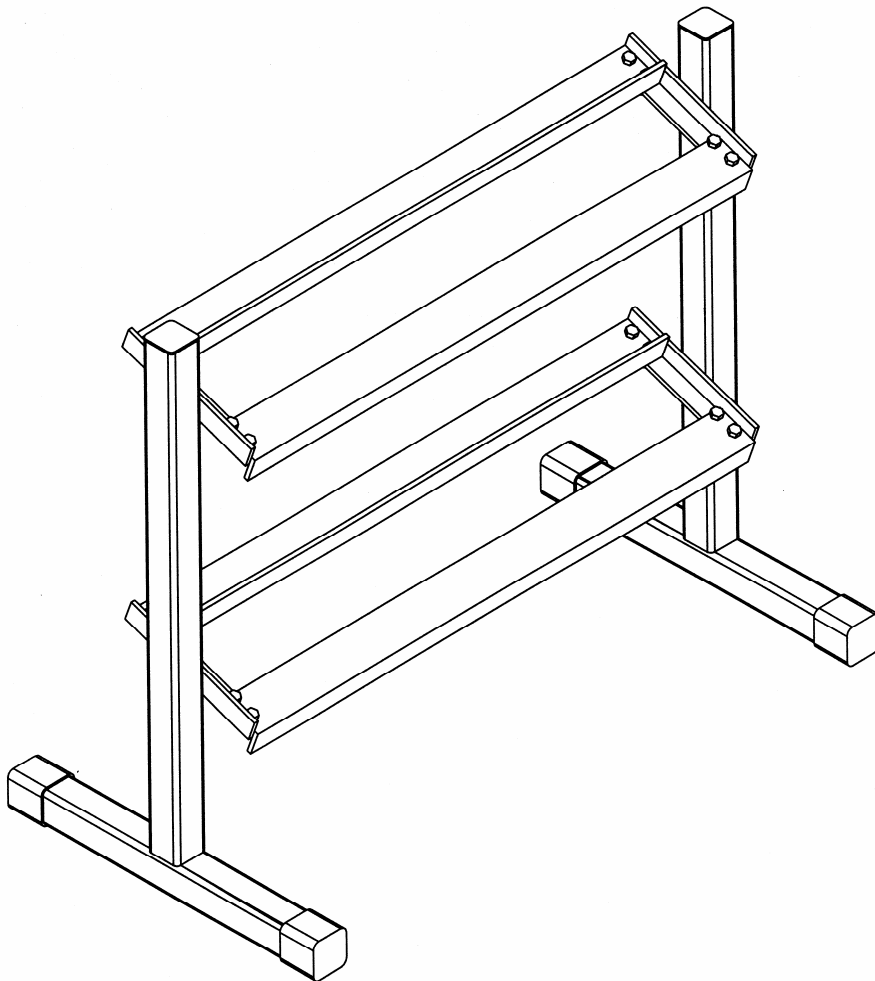

(888) 258-0533

FOR YOUR SAFETY READ ALL INSTRUCTIONS CAREFULLY

*NOTE IF YOU ARE MISSING HARDWARE OR HAVE ANY FIT UP PROBLEMS PLEASE CONTACT DELTECH FITNESS TOLL FREE (888) 258-0533

BOX CONTENTS

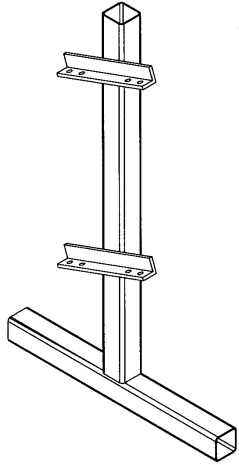

**PART # COM6022
L.H. LEG
QTY 1**

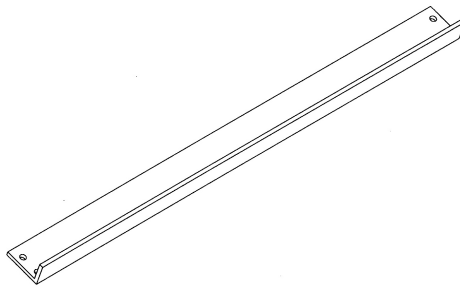

**PART # COM6026
CROSS MEMBER
QTY 4**

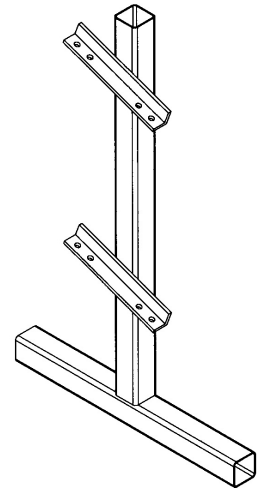

**PART # COM6021
R.H. LEG
QTY 1**

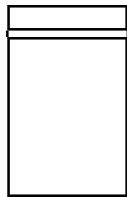

**PART# DF511
HARDWARE
QTY 1**

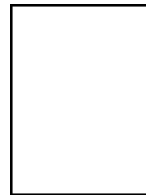

**PART # DF511
INSTRUCTION
SHEET
QTY 1**



*NOTE IF YOU ARE MISSING HARDWARE OR HAVE ANY FIT UP PROBLEMS PLEASE CONTACT DELTECH FITNESS TOLL FREE (888) 258-0533

HARDWARE

(4 PCS) 2" RUBBER CAP

(2 PCS) 2" SQ. CAP

(16 PCS) 3/8" FLANGE NUT

(16 PCS) 3/8" x 1" BOLT



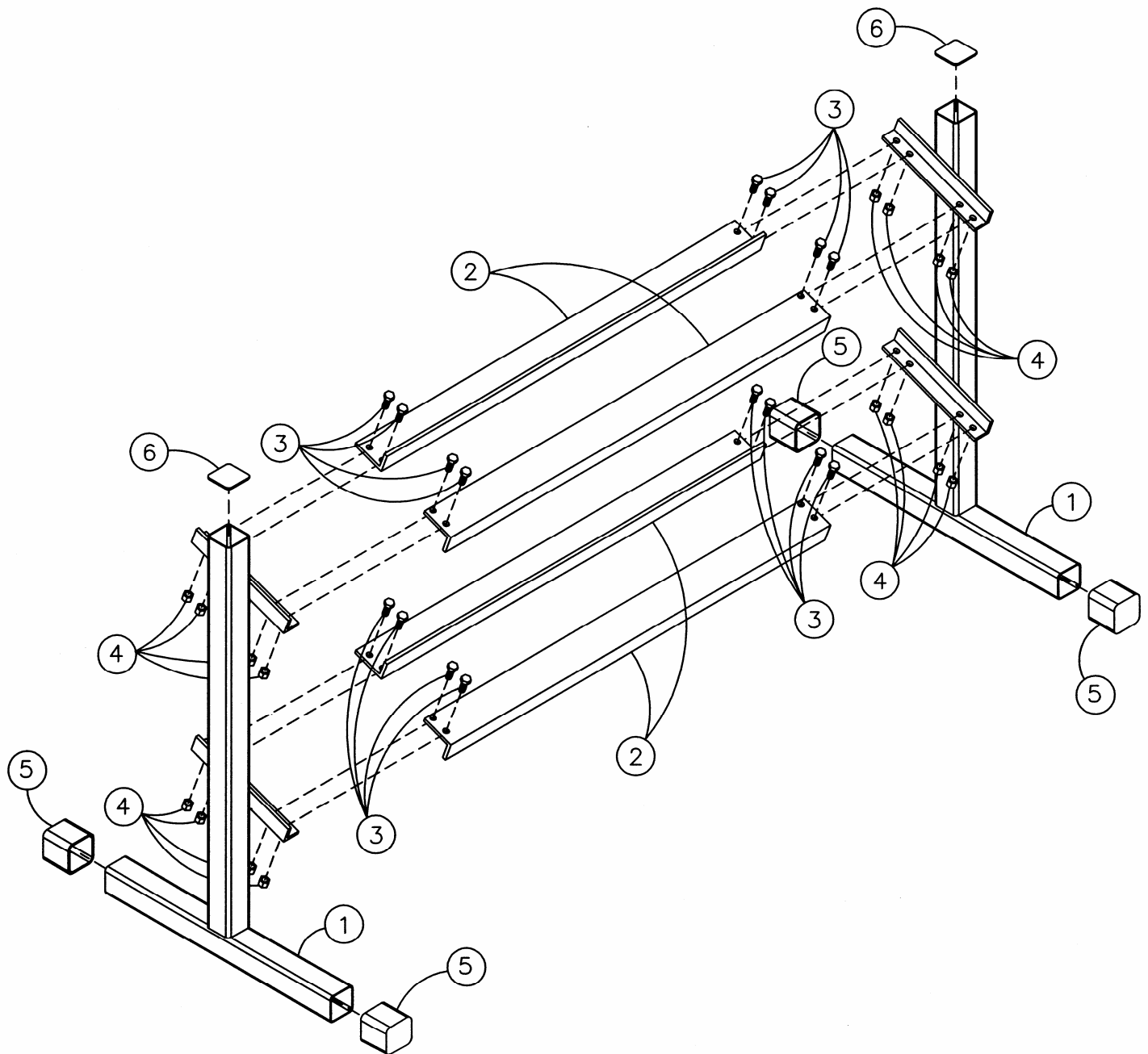

TOOLS REQUIRED:

9/16" WRENCH

TAKE THE DUMBBELL RACK OUT OF THE BOX. NEXT ATTACH THE UPRIGHTS (1) TO THE CROSS MEMBERS (2) USING THE 3/8" x 1" BOLTS (3) AND THE 3/8" LOCKNUTS (4).

NEXT INSTALL 2" END CAPS (6) AND RUBBER SHOES (5).

MAKE MAKE SURE ALL BOLTS ARE TIGHT BEFORE USE.

SAFETY NOTICE

WARNING: THE USER OF THIS WEIGHT EQUIPMENT ASSUMES THE POSSIBILITY OF INJURY BY EXERCISING ON THIS EQUIPMENT. THE POSSIBILITY OF RISK CAN BE REDUCED BY ALWAYS FOLLOWING THESE SIMPLE RULES:

- 1) BEFORE BEGINNING ANY EXERCISE PROGRAM, CONSULT YOUR DOCTOR FOR A COMPLETE PHYSICAL EXAMINATION AND SUGGESTED EXERCISE PROGRAM SPECIFIC FOR YOU.
- 2) STRETCH BEFORE AND AFTER THE EXERCISE PROGRAM, PROPER STRETCHING WILL PREPARE YOUR JOINTS AND MUSCLES FOR EXERCISE AND HELP AVOID INJURIES.
- 3) IF AT ANY TIME YOU SHOULD FEEL FAINT OR DIZZY, NAUSEOUS OR EXPERIENCE ANY OTHER ABNORMAL SYMPTOMS OR DISCOMFORT, DISCONTINUE USE AND CONSULT YOUR DOCTOR.
- 4) DO NOT USE THIS EQUIPMENT WITHOUT QUALIFIED SUPERVISION AND PROPER TRAINING NEVER WORK OUT ALONE ALWAYS HAVE A PARTNER.
- 5) SECURELY TIGHTEN ALL BOLTS AND REGULARLY CHECK TO ENSURE ALL BOLTS HAVE NOT LOOSENED.
- 6) WEAR GOOD RUBBER SOLE SHOES ONLY DO NOT USE BARE FOOTED OR WITH SOCKS ONLY.
- 7) DO NOT WEAR LOOSE CLOTHES SUCH AS ROBES, GOWNS, PANTS, LONG SHIRTS OR JEWELRY WHICH COULD BECOME ENTANGLED IN MOVING PARTS.
- 8) DO NOT STAND OR KNEEL ON SEAT ALWAYS SIT OR LAY SQUARELY CENTERED.
- 9) KEEP HEAD, LIMBS AND BODY PARTS CLEAR OF MOVING PARTS AND WEIGHT PLATES.
- 10) CHILDREN SHOULD NOT USE EXERCISE EQUIPMENT WITHOUT SUPERVISION BECAUSE OF POSSIBILITY OF INJURY FROM IMPROPER USAGE. THIS EQUIPMENT IS INTENDED FOR HOME USE ONLY.
- 11) REPLACEMENT OR WORN OR DEFECTIVE PARTS MUST BE REPLACED WITH FACTORY AUTHORIZED PARTS. IF OTHER THAN FACTORY AUTHORIZED PARTS OR ASSESSORS ARE USED ALL WARRANTIES AND LIABILITIES BECOME VOID.

T-SHIRT ORDER FORM

DELTECH FITNESS T - SHIRT

SIZES AVAILABLE ARE M-XXL. THE COLOR OF THE SHIRTS ARE WHITE. RED AND BLACK LOGO. ONLY \$12.99



DELTECH FITNESS MUSCLE SHIRT

SIZES AVAILABLE M-XXL THE COLOR AVAILABLE IS BLACK. RED AND WHITE LOGO. ONLY \$12.99



SEND TO: DELTECH MANUFACTURING, INC.
3910 OAKLAWN DR.
LOUISVILLE, KY. 40219

ALL ORDERS SHIPPED UPS GROUND.

MAKE CHECK OR MONEY ORDER PAYABLE TO: DELTECH MANUFACTURING
KENTUCKY RESIDENTS ADD 6% SALES TAX. ALLOW 3 WEEKS FOR DELIVERY.
PRICE INCLUDES SHIPPING TO THE CONTIGUOUS UNITED STATES
OR ORDER ONLINE WITH A CREDIT CARD AT WWW.FITNESSDESTINATION.COM

| QTY | SIZE | DESCRIPTION | COLOR | PRICE | TOTAL |
|-----|------|--------------|-------|-------------|-------|
| | | T - SHIRT | WHITE | \$12.99 EA. | |
| | | MUSCLE SHIRT | BLACK | \$12.99 EA. | |
| | | | | TOTAL | |

SHIPPING INFORMATION:
