

ASSEMBLY INSTRUCTIONS FOR THE DF142 OLYMPIC BENCH

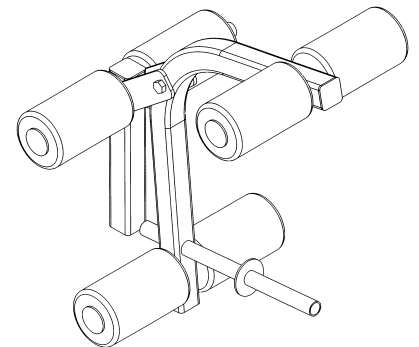
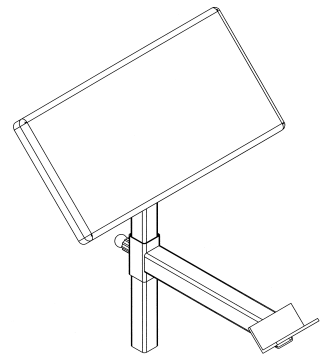
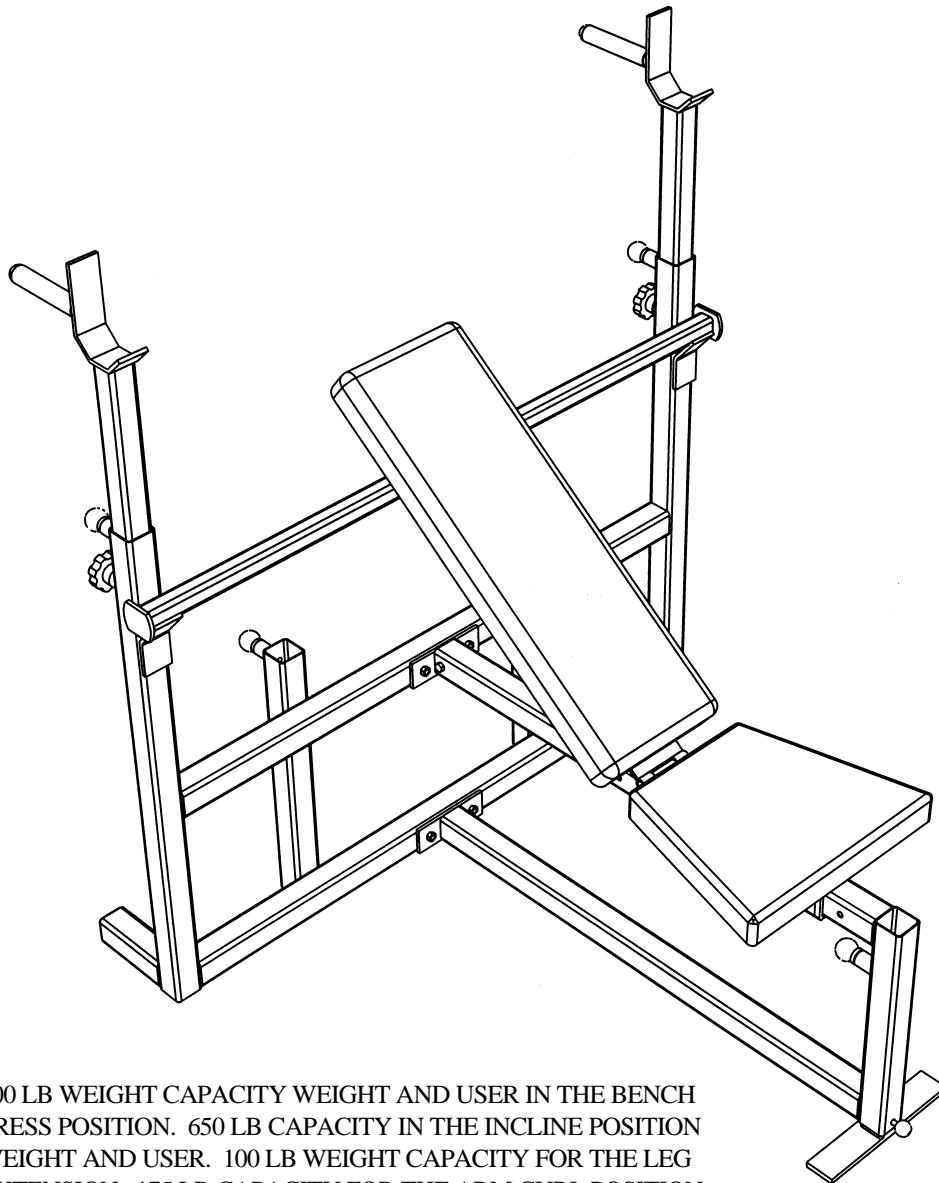

800 LB WEIGHT CAPACITY WEIGHT AND USER IN THE BENCH PRESS POSITION. 650 LB CAPACITY IN THE INCLINE POSITION WEIGHT AND USER. 100 LB WEIGHT CAPACITY FOR THE LEG EXTENSION. 175 LB CAPACITY FOR THE ARM CURL POSITION

(888) 258-0533

FOR YOUR SAFETY READ ALL INSTRUCTIONS CAREFULLY

*NOTE IF YOU ARE MISSING HARDWARE OR HAVE ANY FIT UP PROBLEMS PLEASE CONTACT DELTECH FITNESS TOLL FREE (888) 258-0533

ASSEMBLY INSTRUCTIONS FOR THE DF142 OLYMPIC BENCH

TOOLS REQUIRED:

- 1) 1/2" WRENCH
- 2) 9/16" WRENCHES

INSTRUCTIONS:

- 1) FIRST ASSEMBLE THE SEAT SLIDE USING FIGURE "B AND C USING THE 5/16-18 X 1" BOLTS (3). BEFORE INSTALLING ON THE SEAT FRAME.
- 2) NOW USING FIGURE "A" SLIDE THE FRONT FOOT (7) INTO THE SEAT FRAME (2) USING THE LOCK PIN (14). NEXT SLIDE THE SEAT ASSEMBLY (3) ON THE SEAT FRAME (2). INSTALL THE PULL PIN (12) AND THE TIGHTEN KNOB (13) ON THE SLIDE (3). THEN INSTALL THE PULL PIN (12) ON THE SEAT FRAME (2).
- 3) NEXT ATTACH THE MOUNTING FLANGE (6) ONTO THE WEIGHT COLUMN (1) USING THE 3/8"-16 X 3" BOLTS (8), 3/8" WASHERS, AND 3/8-16 NUTS (9). NOW ATTACH THE SEAT FRAME ASSEMBLY (2) TO THE WEIGHT COLUMN (1) USING THE 3/8"-16 X 3" BOLTS (8), 3/8" WASHERS, AND 3/8-16 NUTS (9).
- 4) INSTALL THE PULL PIN (12) INTO THE WEIGHT COLUMN (1) AND SLIDE THE WEIGHT BAR HOLDERS (4) INTO THE WEIGHT COLUMN (1). NOW PUSH THE 1" GRIPS (11) ONTO THE WEIGHT BAR HOLDERS (4) *NOTE: THE GRIPS WILL SLIDE ON EASIER IF YOU MOISTEN THE TUBE WITH A SPONGE BEFORE INSTALLATION.*
- 5) MAKE SURE ALL THE BOLTS ARE TIGHT BEFORE USE. REMEMBER TO CHECK THEM PERIODICALLY TO MAKE SURE THEY ALWAYS STAY TIGHT.

FIGURE D

- 1) ASSEMBLE THE LEG SWING (1) TO THE YOKE POST (2) USING THE 1/2"-13 X 3 1/4" BOLT (5) AND THE 1/2"-13 NUT (6).
- 2) SLIDE THE PAD TUBES (4) THROUGH THE LEG SWING (1) AND THE YOKE POST (2). NEXT SLIDE THE PADS (3) ONTO THE LEG PAD TUBES (4). THEN SECURE THE PADS (3) USING THE MUSHROOM CAP (9).
- 3) INSTALL THE 1 3/4" SQUARE CAPS (8) INTO THE LEG SWING (1) AND THE YOKE POST (2). NOW INSTALL THE 1" RD CAP (7) INTO THE LEG SWING (1). FINALLY INSTALL THE BUMPER (10) ON THE BACK OF THE LEG SWING (1).

FIGURE E

- 1) ASSEMBLE THE PAD (E) TO THE FRAME (C) USING THE 1/4"-20 X 3/4" BOLTS (D) AND THE FLAT WASHERS.
- 2) NEXT SLIDE THE BAR HOLDER (A) ON THE ARM PAD FRAME (C) AND SCREW IN THE PULL PIN (B).

ASSEMBLY INSTRUCTIONS FOR THE DF142 OLYMPIC BENCH

WARNING: THE USER OF THIS WEIGHT EQUIPMENT ASSUMES THE POSSIBILITY OF INJURY BY EXERCISING ON THIS EQUIPMENT. THE POSSIBILITY OF RISK CAN BE REDUCED BY ALWAYS FOLLOWING THESE SIMPLE RULES:

- 1) BEFORE BEGINNING ANY EXERCISE PROGRAM, CONSULT YOUR DOCTOR FOR A COMPLETE PHYSICAL EXAMINATION AND SUGGESTED EXERCISE PROGRAM SPECIFIC FOR YOU.
- 2) STRETCH BEFORE AND AFTER THE EXERCISE PROGRAM, PROPER STRETCHING WILL PREPARE YOUR JOINTS AND MUSCLES FOR EXERCISE AND HELP AVOID INJURIES.
- 3) IF AT ANY TIME YOU SHOULD FEEL FAINT OR DIZZY, NAUSEOUS OR EXPERIENCE ANY OTHER ABNORMAL SYMPTOMS OR DISCOMFORT, DISCONTINUE USE AND CONSULT YOUR DOCTOR.
- 4) DO NOT USE THIS EQUIPMENT WITHOUT QUALIFIED SUPERVISION AND PROPER TRAINING NEVER WORK OUT ALONE ALWAYS HAVE A PARTNER.
- 5) SECURELY TIGHTEN ALL BOLTS AND REGULARLY CHECK TO ENSURE ALL BOLTS HAVE NOT LOOSENED.
- 6) WEAR GOOD RUBBER SOLE SHOES ONLY DO NOT USE BARE FOOTED OR WITH SOCKS ONLY.
- 7) DO NOT WEAR LOOSE CLOTHES SUCH AS ROBES, GOWNS, PANTS, LONG SHIRTS OR JEWELRY WHICH COULD BECOME ENTANGLED IN MOVING PARTS.
- 8) DO NOT STAND OR KNEEL ON SEAT ALWAYS SIT OR LAY SQUARELY CENTERED.
- 9) KEEP HEAD, LIMBS AND BODY PARTS CLEAR OF MOVING PARTS AND WEIGHT PLATES.
- 10) CHILDREN SHOULD NOT USE EXERCISE EQUIPMENT WITHOUT SUPERVISION BECAUSE OF POSSIBILITY OF INJURY FROM IMPROPER USAGE. THIS EQUIPMENT IS INTENDED FOR HOME USE ONLY.
- 11) REPLACEMENT OR WORN OR DEFECTIVE PARTS MUST BE REPLACED WITH FACTORY AUTHORIZED PARTS. IF OTHER THAN FACTORY AUTHORIZED PARTS OR ASSESSORS ARE USED ALL WARRANTIES AND LIABILITIES BECOME VOID.

ADJUSTING THE BACK PAD: RAISE AND LOWER THE BACKREST USING THE PULL PIN IN THE SEAT SLIDE. MAKE SURE THE PULL PIN IS ENGAGED IN THE ADJUSTMENT HOLE.

ADJUSTING THE SEAT PAD: RAISE THE SEAT PAD TO THE DESIRED POSITION BY USING THE PULL PIN THROUGH THE HOLES IN THE BRACKET.

ADJUSTING THE WEIGHT ARMS: RAISE AND LOWER THE WEIGHT ARMS USING THE PULL PIN. MAKE SURE THE PULL PIN IS ENGAGED IN THE ADJUSTMENT HOLE.

ADJUSTING THE ARM PAD: RAISE AND LOWER THE PAD USING THE PULL PIN. TURN THE KNOB TO LOOSEN FOR ADJUSTMENT MAKE SURE THE PULL PIN IS SECURE IN THE ADJUSTMENT HOLE THEN TURN THE KNOB TO TIGHTEN BEFORE USE.

ADJUSTING THE DECLINE: RAISE AND LOWER THE WEIGHT BENCH USING THE LOCK PIN IN THE HOLE AT THE DESIRED HEIGHT . MAKE SURE THE LOCK PIN IS THROUGH BOTH SIDES OF THE TUBE BEFORE USE.

ASSEMBLY INSTRUCTIONS FOR THE DF142 OLYMPIC BENCH

NOTE: #5 INCLINE BAR IS REMOVED FOR THE
FLAT BENCH POSITION

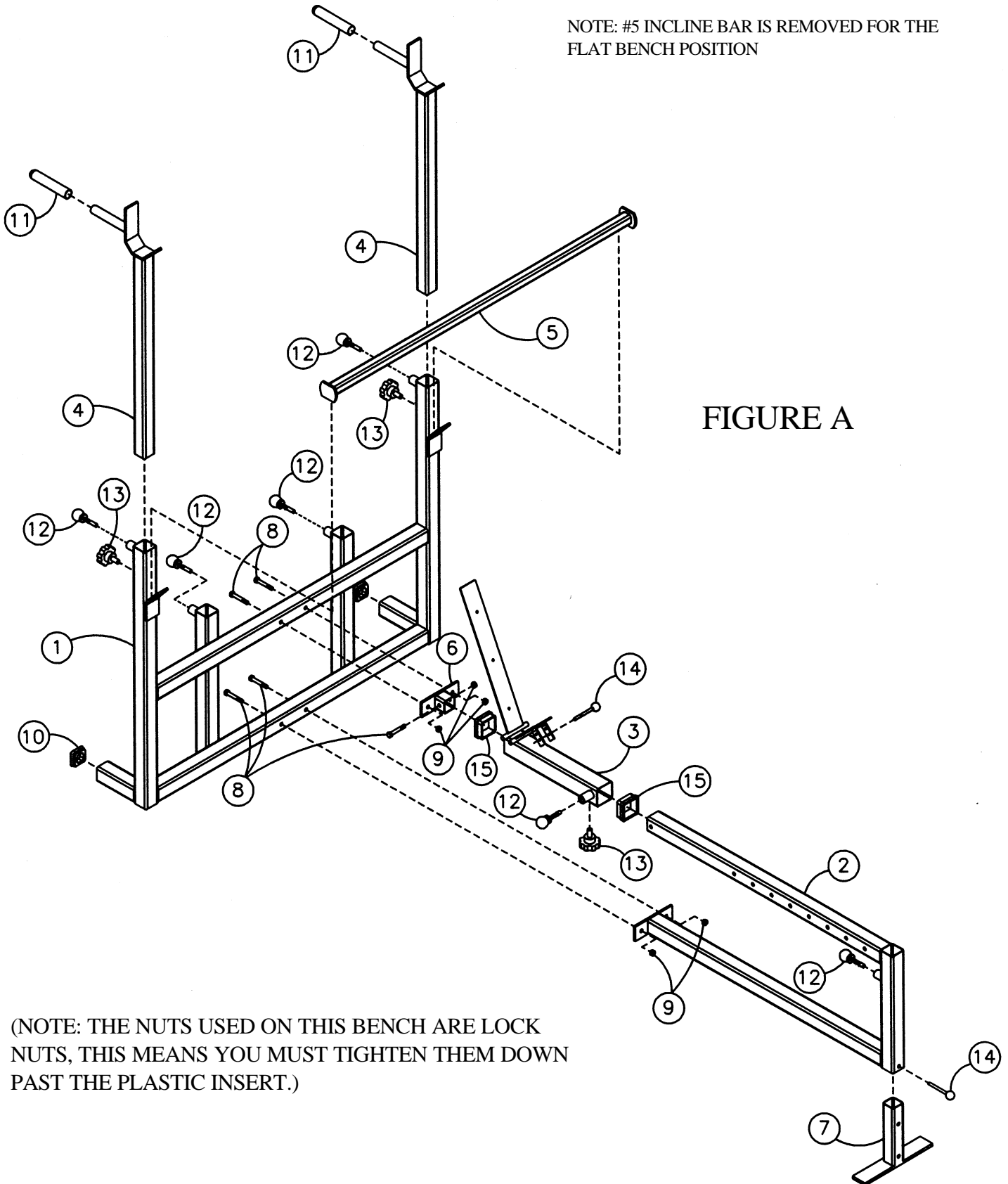

FIGURE A

(NOTE: THE NUTS USED ON THIS BENCH ARE LOCK
NUTS, THIS MEANS YOU MUST TIGHTEN THEM DOWN
PAST THE PLASTIC INSERT.)

ASSEMBLY INSTRUCTIONS FOR THE DF142 OLYMPIC BENCH

FIGURE B

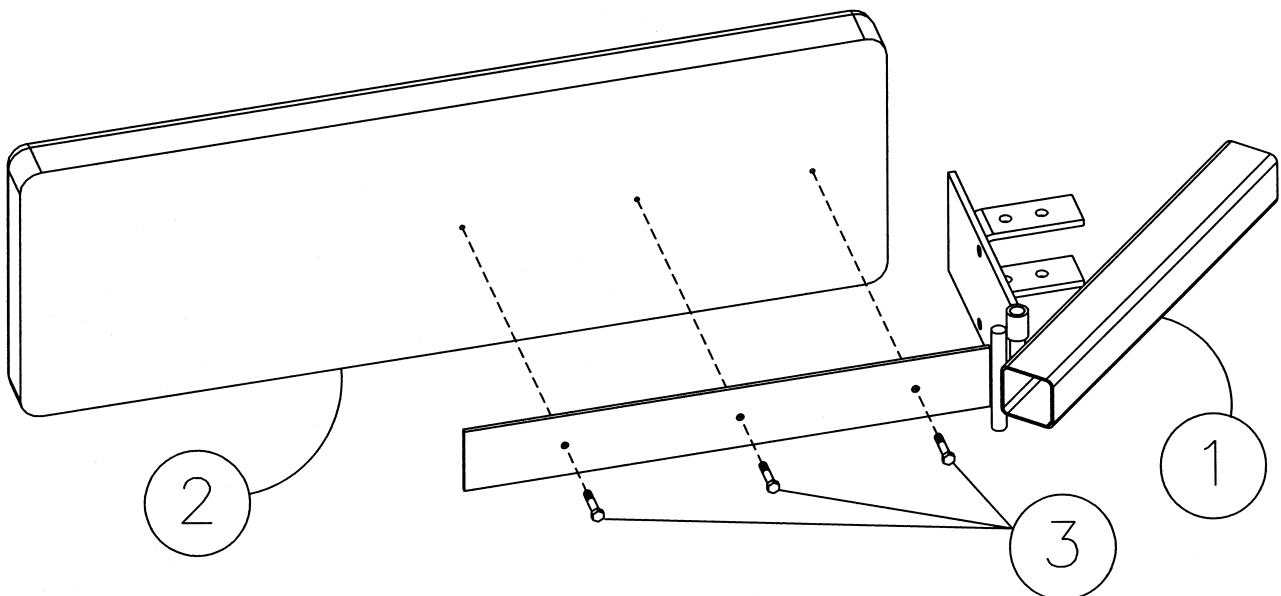
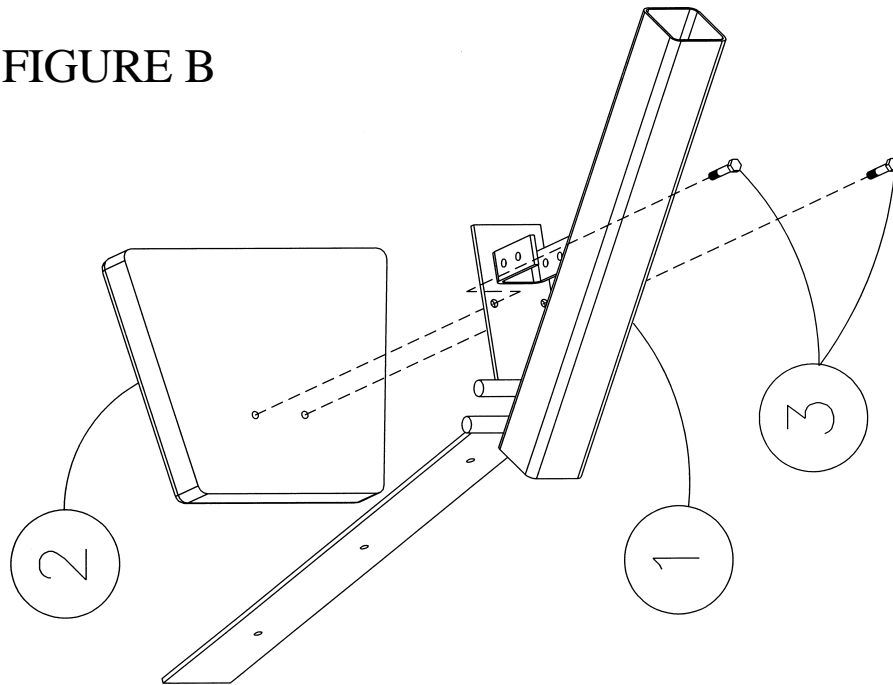
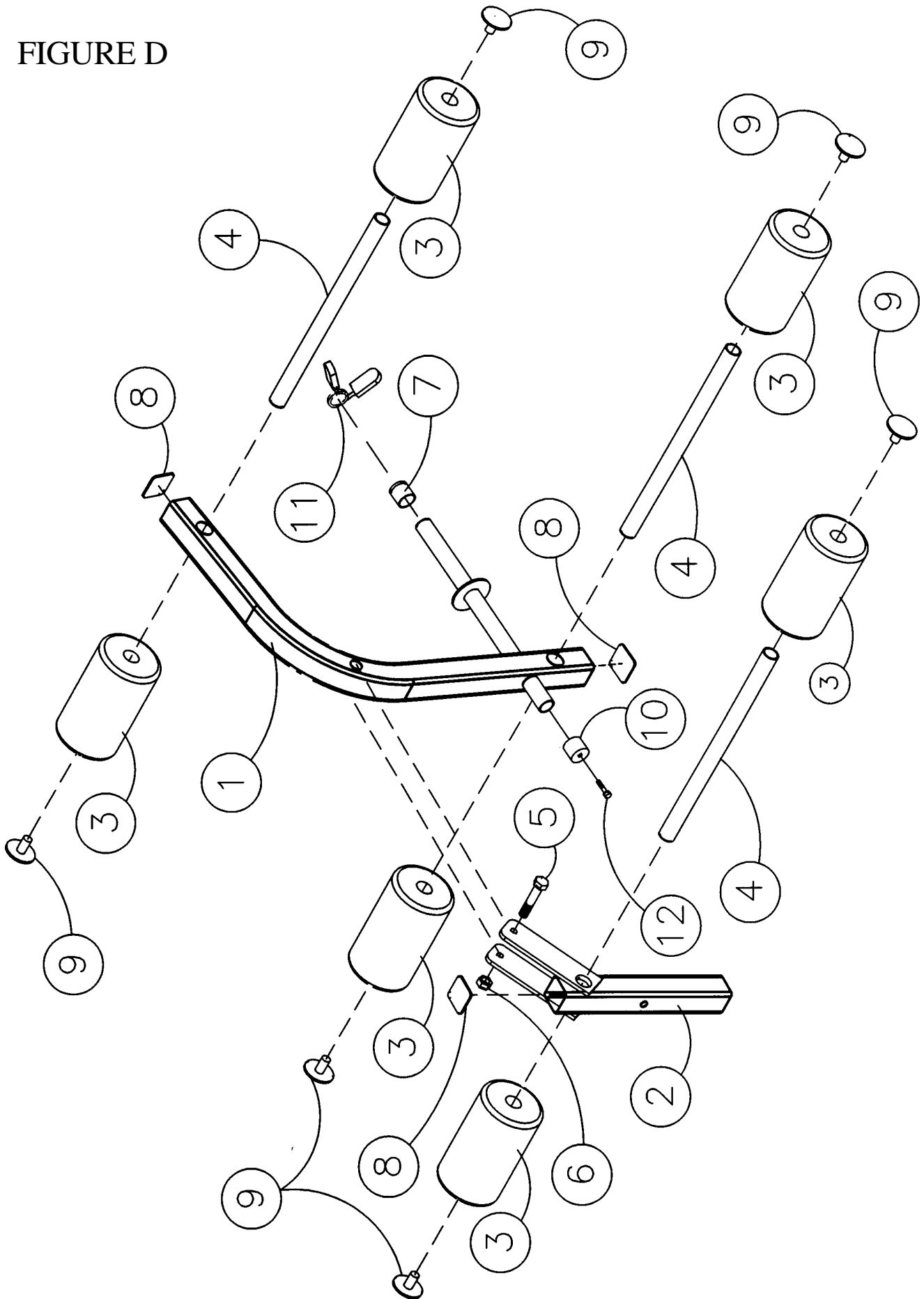

FIGURE C

FIGURE D



ASSEMBLY INSTRUCTIONS FOR THE DF142 OLYMPIC BENCH

FIGURE E

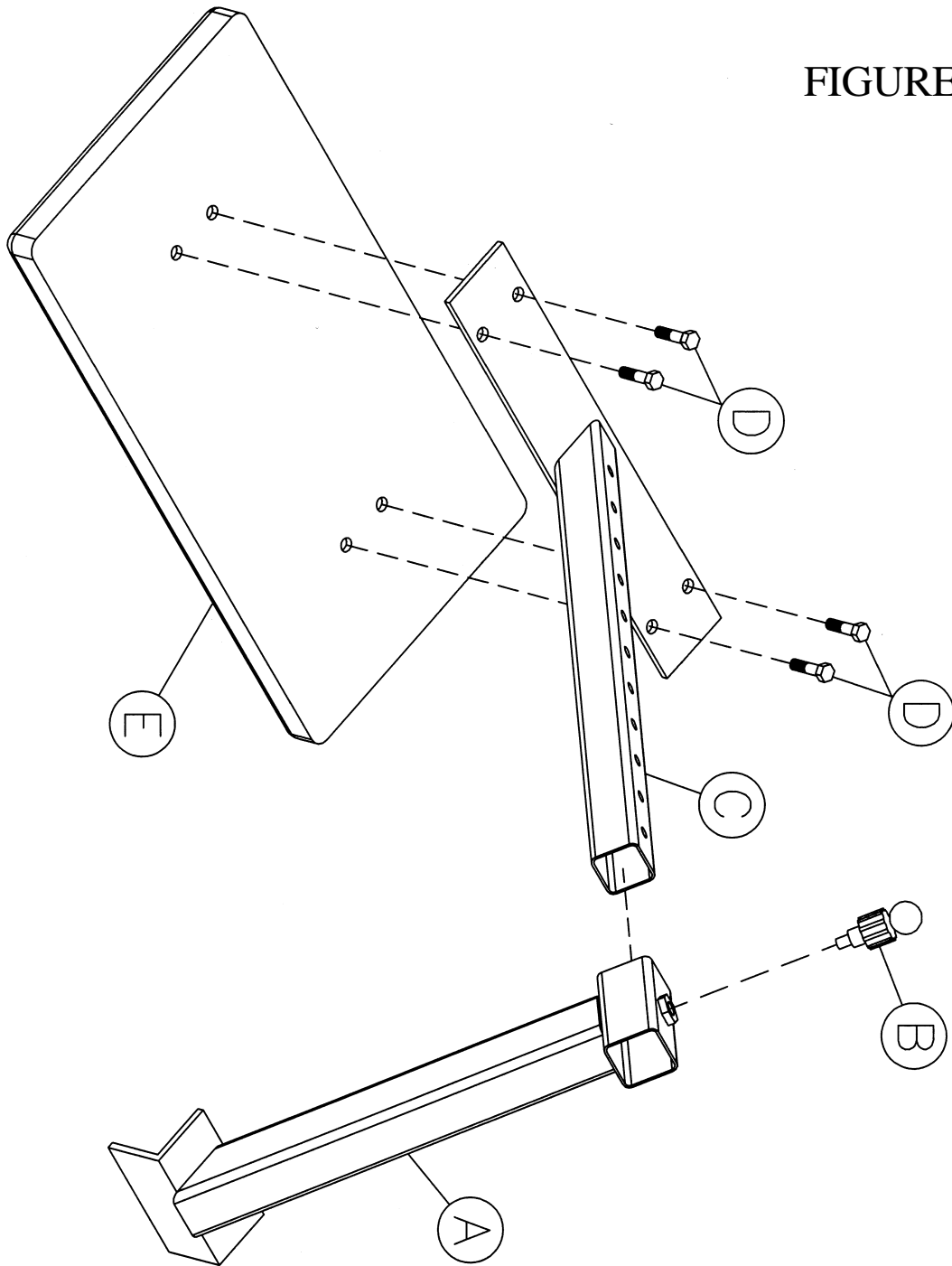

ASSEMBLY INSTRUCTIONS FOR THE DF142 OLYMPIC BENCH

BOX CONTENTS



PART # DF141-50
BRACKET
QTY 1

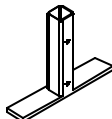

PART # DF141-40
FOOT
QTY 1

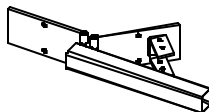

PART # DF141-70
SLIDE
QTY 1

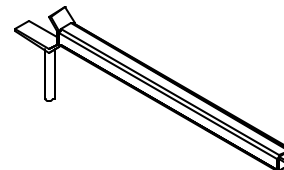

PART # DF141-30
WEIGHT CRADLE
QTY 2

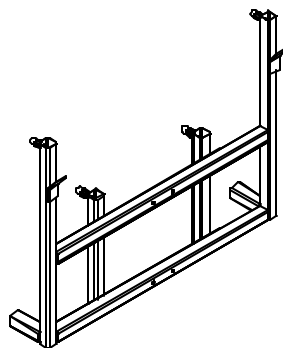

PART # DF142-10
WEIGHT COLUMN
QTY 1

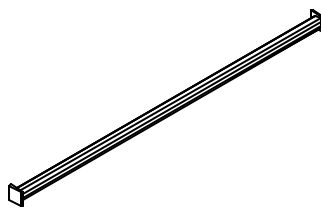

PART # DF142-60
INCLINE ROD
QTY 1

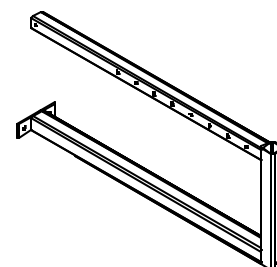

PART # DF141-20
SEAT FRAME
QTY 1

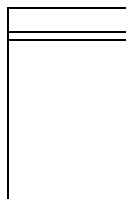

PART # DF142
HARDWARE PACK
QTY 1

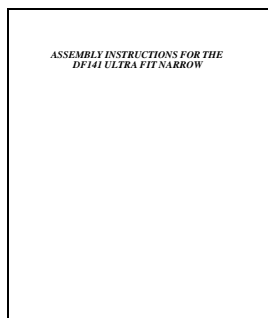

PART # DF142
INSTRUCTIONS
QTY 1

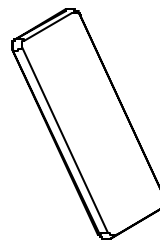

PART # COM8014
BACKREST
QTY 1

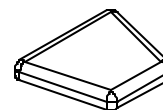

PART # COM8015
SEAT
QTY 1

ASSEMBLY INSTRUCTIONS FOR THE DF142 OLYMPIC BENCH

BOX CONTENTS

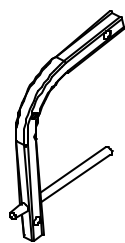

**PART # COM6000
LEG SWING
QTY 1**

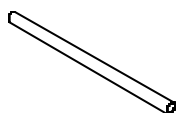

**PART # COM7001
LEG PAD TUBE
QTY 3**



**4" X 8" ROLLER
PAD
QTY 6**

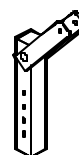

**PART # COM6005
YOKE
QTY 1**

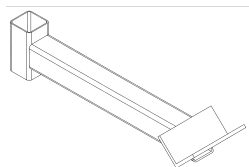

**PART # DF105-20
BAR SUPPORT
QTY 1**

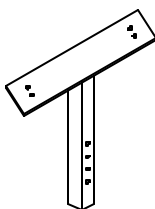

**PART # DF105-10
ARM SUPPORT
QTY 1**

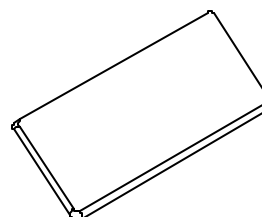

**PART # COM8016
ARMREST
QTY 1**

*NOTE IF YOU ARE MISSING HARDWARE OR HAVE ANY FIT UP PROBLEMS PLEASE CONTACT DELTECH FITNESS TOLL FREE (888) 258-0533

ASSEMBLY INSTRUCTIONS FOR THE DF142 OLYMPIC BENCH

(2 PCS) 2" SQ. CAP

(6 PCS) 3/8" X 1" TURN KNOB

(4 PCS) 1/4" FLAT WASHER

(1 PCS) 1/2"-13 X 2 3/4" BOLT

(4 PCS) 5/16" - 18 X 1" BOLT

(4 PCS) 5/16" WASHER

(6 PCS) 1/2"-13 NUT

(5 PCS) 1/2"-13 X 3" BOLT

(6 PCS) MUSHROOM CAP

(4 PCS) 1/4 - 20 X 1" BOLT

(2 PCS) 3 1/4" LOCK PIN

(6 PCS) PULL PIN BALL STYLE

(2 PCS) HANDLE GRIP

(12 PCS) 1/2" WASHER

(2 PCS) REDUCERS

(1 PC) 1" QUICK CLAMP

(3 PCS) 1 3/4" SQ. CAP

(1 PC) 1" RD. BUMPER

(1 PCS) 1" RD. INSIDE CAP

(1 PC) PULL PIN

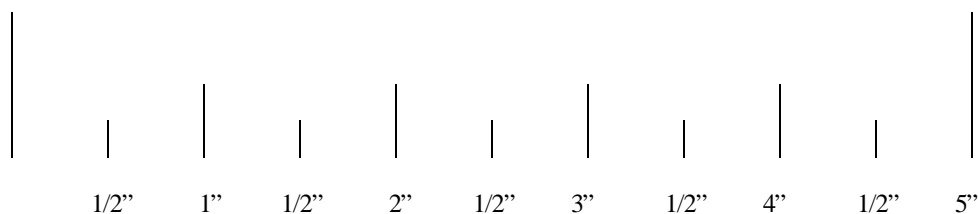

(888) 258-0533

FOR YOUR SAFETY READ ALL INSTRUCTIONS CAREFULLY

T-SHIRT ORDER FORM

DELTECH FITNESS T - SHIRT

SIZES AVAILABLE ARE M-XXL. THE COLOR OF THE SHIRTS ARE WHITE. RED AND BLACK LOGO. ONLY \$12.99



DELTECH FITNESS MUSCLE SHIRT

SIZES AVAILABLE M-XXL THE COLOR AVAILABLE IS BLACK. RED AND WHITE LOGO. ONLY \$12.99

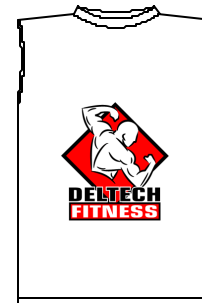

SEND TO: DELTECH MANUFACTURING, INC.
3910 OAKLAWN DR.
LOUISVILLE, KY. 40219

ALL ORDERS SHIPPED UPS GROUND.

MAKE CHECK OR MONEY ORDER PAYABLE TO: DELTECH MANUFACTURING
KENTUCKY RESIDENTS ADD 6% SALES TAX. ALLOW 3 WEEKS FOR DELIVERY.

PRICE INCLUDES SHIPPING TO THE CONTIGUOUS UNITED STATES
OR ORDER ONLINE WITH A CREDIT CARD AT WWW.FITNESSDESTINATION.COM

QTY	SIZE	DESCRIPTION	COLOR	PRICE	TOTAL
		T - SHIRT	WHITE	\$12.99 EA.	
		MUSCLE SHIRT	BLACK	\$12.99 EA.	
				TOTAL	

SHIPPING INFORMATION:
