

ASSEMBLY INSTRUCTIONS FOR THE DF1175 LEG DEVELOPER

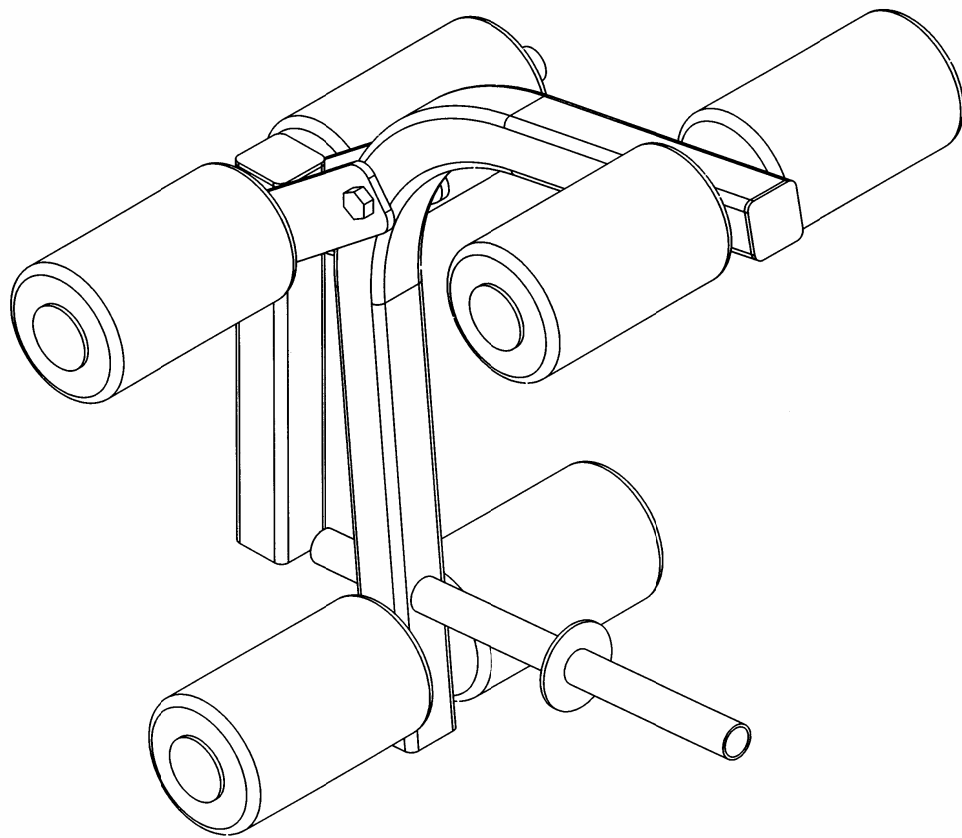

(888) 258-0533

FOR YOUR SAFETY READ ALL INSTRUCTIONS CAREFULLY

*NOTE IF YOU ARE MISSING HARDWARE OR HAVE ANY FIT UP PROBLEMS PLEASE CONTACT DELTECH FITNESS TOLL FREE (888) 258-0533

BOX CONTENTS

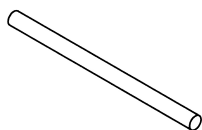

**PART # COM7001
ROLLER PAD TUBE
QTY 3**

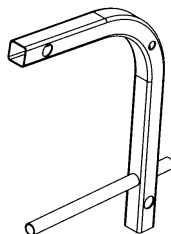

**PART # COM6000
LEG EXTENSION FRAME
QTY 1**

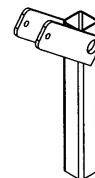

**PART # COM6005
LEG EXTENSION YOKE
QTY 1**

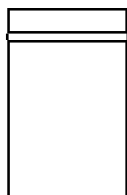

**PART # DF1175
HARDWARE PACK
QTY 1**

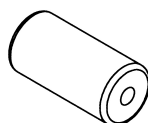

**4" X 8" ROLLER PAD
QTY 6**

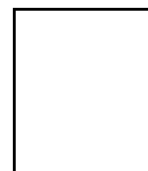

**DF1175
INSTRUCTIONS
QTY 1**

(888) 258-0533

FOR YOUR SAFETY READ ALL INSTRUCTIONS CAREFULLY

*NOTE IF YOU ARE MISSING HARDWARE OR HAVE ANY FIT UP PROBLEMS PLEASE CONTACT DELTECH FITNESS TOLL FREE (888) 258-0533

HARDWARE

(1 PCS) ½” NUT

(1 PCS) ½” x 3” BOLT

(6 PCS) MUSHROOM CAP

(1 PC) 1” QUICK CLAMP

(3 PCS) 1 ¾” SQ. CAP

(1 PC) 1” ROUND BUMPER

(1 PCS) 1” ROUND INSIDE CAP

(888) 258-0533

FOR YOUR SAFETY READ ALL INSTRUCTIONS CAREFULLY

*NOTE IF YOU ARE MISSING HARDWARE OR HAVE ANY FIT UP PROBLEMS PLEASE CONTACT DELTECH FITNESS TOLL FREE (888) 258-0533

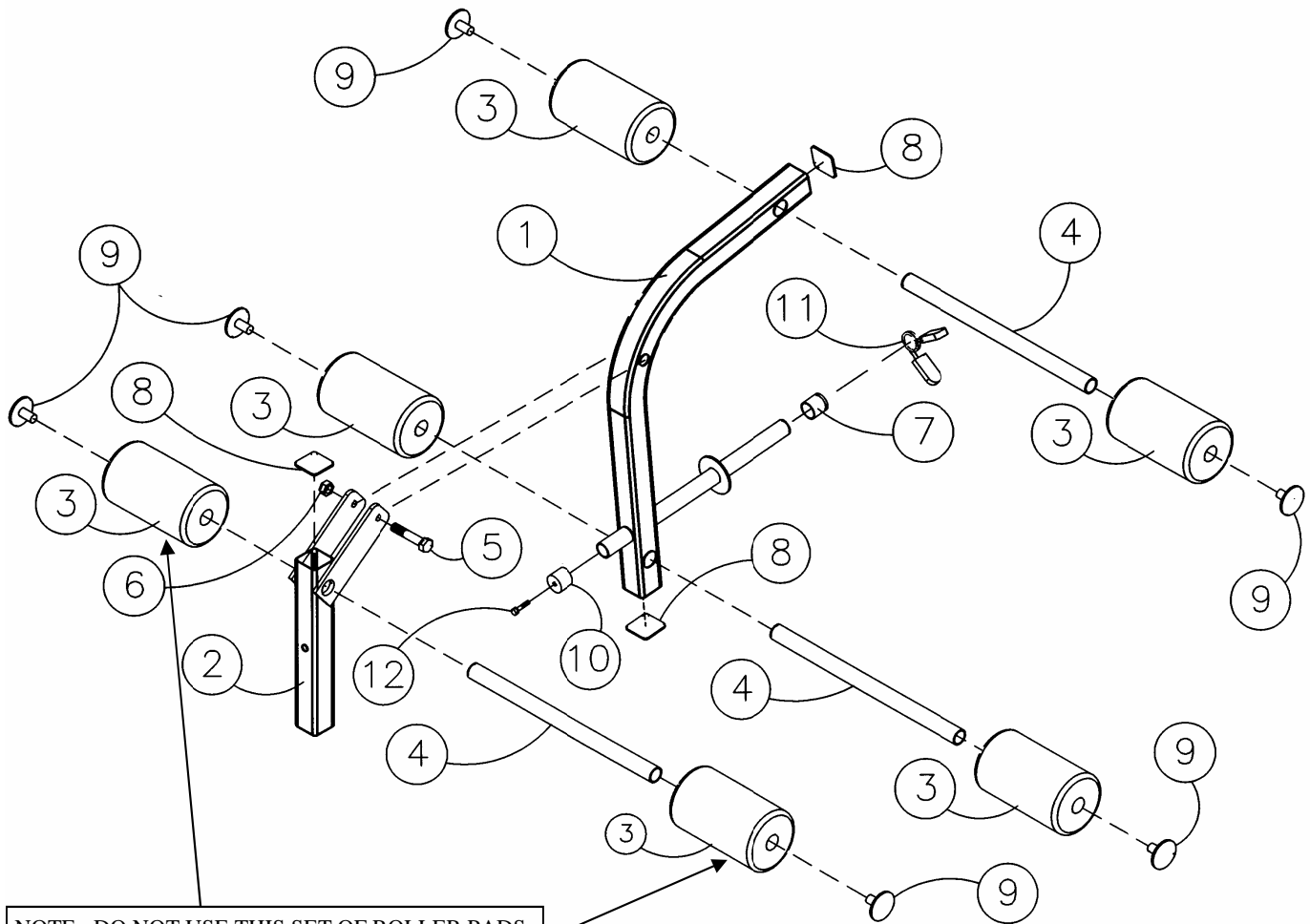

NOTE: DO NOT USE THIS SET OF ROLLER PADS WHEN USING THIS ATTACHMENT WITH THE DF102 BENCH

ASSEMBLE THE LEG EXTENSION FRAME (1) TO THE YOKE POST (2) USING THE 1/2" x 3/4" BOLT (5) AND THE 1/2" NUT (6).

SLIDE THE ROLLER PAD TUBES (4) THROUGH THE LEG EXTENSION FRAME (1) AND THE YOKE POST (2). NEXT SLIDE THE ROLLER PADS (3) ONTO THE ROLLER PAD TUBES (4). THEN SECURE THE ROLLER PADS (3) USING THE MUSHROOM CAP (9).

INSTALL THE 1 3/4" SQUARE CAPS (8) INTO THE LEG EXTENSION FRAME (1) AND THE YOKE POST (2). INSTALL THE 1" ROUND CAP (7) INTO THE LEG EXTENSION FRAME (1).

FINALLY INSTALL THE BUMPER (10) ON THE BACK OF THE LEG EXTENSION FRAME (1).

MAKE SURE ALL THE BOLTS ARE TIGHT BEFORE USE. REMEMBER TO CHECK THEM PERIODICALLY TO MAKE SURE THEY ALWAYS STAY TIGHT.

SAFETY NOTICE

WARNING: THE USER OF THIS WEIGHT EQUIPMENT ASSUMES THE POSSIBILITY OF INJURY BY EXERCISING ON THIS EQUIPMENT. THE POSSIBILITY OF RISK CAN BE REDUCED BY ALWAYS FOLLOWING THESE SIMPLE RULES:

- 1) BEFORE BEGINNING ANY EXERCISE PROGRAM, CONSULT YOUR DOCTOR FOR A COMPLETE PHYSICAL EXAMINATION AND SUGGESTED EXERCISE PROGRAM SPECIFIC FOR YOU.
- 2) STRETCH BEFORE AND AFTER THE EXERCISE PROGRAM, PROPER STRETCHING WILL PREPARE YOUR JOINTS AND MUSCLES FOR EXERCISE AND HELP AVOID INJURIES.
- 3) IF AT ANY TIME YOU SHOULD FEEL FAINT OR DIZZY, NAUSEOUS OR EXPERIENCE ANY OTHER ABNORMAL SYMPTOMS OR DISCOMFORT, DISCONTINUE USE AND CONSULT YOUR DOCTOR.
- 4) DO NOT USE THIS EQUIPMENT WITHOUT QUALIFIED SUPERVISION AND PROPER TRAINING NEVER WORK OUT ALONE ALWAYS HAVE A PARTNER.
- 5) SECURELY TIGHTEN ALL BOLTS AND REGULARLY CHECK TO ENSURE ALL BOLTS HAVE NOT LOOSENED.
- 6) WEAR GOOD RUBBER SOLE SHOES ONLY DO NOT USE BARE FOOTED OR WITH SOCKS ONLY.
- 7) DO NOT WEAR LOOSE CLOTHES SUCH AS ROBES, GOWNS, PANTS, LONG SHIRTS OR JEWELRY WHICH COULD BECOME ENTANGLED IN MOVING PARTS.
- 8) DO NOT STAND OR KNEEL ON SEAT ALWAYS SIT OR LAY SQUARELY CENTERED.
- 9) KEEP HEAD, LIMBS AND BODY PARTS CLEAR OF MOVING PARTS AND WEIGHT PLATES.
- 10) CHILDREN SHOULD NOT USE EXERCISE EQUIPMENT WITHOUT SUPERVISION BECAUSE OF POSSIBILITY OF INJURY FROM IMPROPER USAGE. THIS EQUIPMENT IS INTENDED FOR HOME USE ONLY.
- 11) REPLACEMENT OR WORN OR DEFECTIVE PARTS MUST BE REPLACED WITH FACTORY AUTHORIZED PARTS. IF OTHER THAN FACTORY AUTHORIZED PARTS OR ASSESSORS ARE USED ALL WARRANTIES AND LIABILITIES BECOME VOID.

T-SHIRT ORDER FORM

DELTECH FITNESS T - SHIRT

SIZES AVAILABLE ARE M-XXL. THE COLOR OF THE SHIRTS ARE WHITE. RED AND BLACK LOGO. ONLY \$12.99



DELTECH FITNESS MUSCLE SHIRT

SIZES AVAILABLE M-XXL THE COLOR AVAILABLE IS BLACK. RED AND WHITE LOGO. ONLY \$12.99



**SEND TO: DELTECH MANUFACTURING, INC.
3910 OAKLAWN DR.
LOUISVILLE, KY. 40219**

ALL ORDERS SHIPPED UPS GROUND.

**MAKE CHECK OR MONEY ORDER PAYABLE TO: DELTECH MANUFACTURING
KENTUCKY RESIDENTS ADD 6% SALES TAX. ALLOW 3 WEEKS FOR DELIVERY.**

**PRICE INCLUDES SHIPPING TO THE CONTIGUOUS UNITED STATES
OR ORDER ONLINE WITH A CREDIT CARD AT WWW.FITNESSDESTINATION.COM**

QTY	SIZE	DESCRIPTION	COLOR	PRICE	TOTAL
		T - SHIRT	WHITE	\$12.99 EA.	
		MUSCLE SHIRT	BLACK	\$12.99 EA.	
				TOTAL	

SHIPPING INFORMATION:
